



INSTALLATION MANUAL

Elevation™ Series (EX36 illustrated)

SAFETY INFORMATION

⚠ WARNING

FIRE OR EXPLOSION HAZARD

Failure to follow safety warnings exactly could result in serious injury, death, or property damage.

- Do not store or use gasoline or other flammable vapours and liquids in the vicinity of this or any other appliance.

-WHAT TO DO IF YOU SMELL GAS:

- Do not try to light any appliance.
- Do not touch any electrical switch; do not use any phone in your building.
- Leave the building immediately.
- Immediately call your gas supplier from a neighbour's phone. Follow the gas supplier's instructions.
- If you cannot reach your gas supplier, call the fire department.

- Installation and service must be performed by a qualified installer, service agency, or the supplier.

This appliance may be installed in an aftermarket, permanently located, manufactured home (USA only) or mobile home, where not prohibited by local codes.

This appliance is only for use with the type of gas indicated on the rating plate. This appliance is not convertible for use with other gases, unless a certified kit is used.

INSTALLER: Leave this manual with the appliance.

CONSUMER: Retain this manual for future reference.

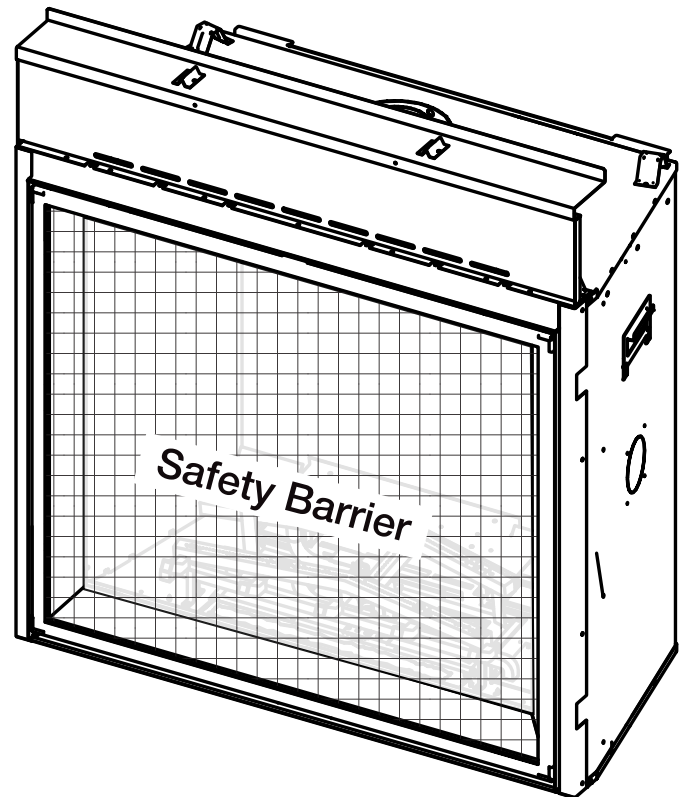

THIS APPLIANCE IS SUITABLE FOR THE OPTIONAL DYNAMIC HEAT CONTROL™ SYSTEM
(See Dynamic Heat Control™ installation manual)



FOR INDOOR USE ONLY

**CERTIFIED TO THE CANADIAN AND AMERICAN NATIONAL STANDARDS:
CSA 2.22 AND ANSI Z21.50 FOR VENTED DECORATIVE GAS APPLIANCES**



**PLACE BARCODE LABEL ON
THE OWNER'S MANUAL**

Wolf Steel Ltd., 24 Napoleon Rd., Barrie, ON, L4M 0G8 Canada / 103 Miller Drive, Crittenden, Kentucky, USA, 41030
Phone 1 (866) 820-8686 • www.napoleon.com • hearth@napoleon.com

WARNING

- **This appliance is hot when operated and can cause severe burns if contacted.**
- **Any changes or alterations to this appliance or its controls can be dangerous and is prohibited.**
- Do not operate appliance before reading and understanding operating instructions. Failure to operate appliance according to operating instructions could cause fire or injury.
- Ensure the glass door is opened or removed when lighting the pilot for the first time and when the gas supply has run out.
- Risk of fire or asphyxiation, do not operate appliance with fixed glass removed and never obstruct the front opening of the appliance.
- Do not connect 110 volts to the control valve, with the exception of models; GSST8 and GT8.
- Risk of burns. The appliance should be turned off and cooled before servicing.
- Do not install damaged, incomplete or substitute components.
- Risk of cuts and abrasions. Wear protective gloves, protective footwear, and safety glasses during installation. Sheet metal edges may be sharp.
- Do not burn wood or other materials in this appliance.
- Provide adequate ventilation and combustion air. Provide adequate accessibility clearance for servicing and operating the appliance.
- High pressure will damage valve. Disconnect gas supply piping before pressure testing gas line at test pressures above 1/2 psig. Close the manual shut-off valve before pressure testing gas line at test pressures equal to or less than 1/2 psig (35mb).
- The appliance must not be operated at temperatures below freezing (32°F / 0°C). Allow the appliance to warm to above freezing prior to operation, with the exception of the outdoor models; these appliances are suitable for 0°F / -18°C.
- **Children and adults should be alerted to hazards of high surface temperature and should stay away to avoid burns or clothing ignition.**
- **Young children should be carefully supervised when they are in the same room as the appliance. Toddlers, young children and others may be susceptible to accidental contact burns. A physical barrier is recommended if there are at risk individuals in the house. To restrict access to an appliance or stove, install an adjustable safety gate to keep toddlers, young children and other at risk individuals out of the room and away from hot surfaces.**
- **Clothing or other flammable material should not be placed on or near the appliance.**
- **Due to high temperatures, the appliance should be located out of traffic and away from furniture and draperies.**
- Furniture or other objects must be kept a minimum of 4 feet (1.22m) away from the front of the appliance.
- Ensure you have incorporated adequate safety measures to protect infants/toddlers from touching hot surfaces.
- Even after the appliance is off, it will remain hot for an extended period of time.
- Check with your local hearth specialty dealer for safety screens and hearth guards to protect children from hot surfaces. These screens and guards must be fastened to the floor.
- **Any safety screen, guard or barrier removed for servicing the appliance, must be replaced prior to operating the appliance.**
- It is imperative that the control compartments, burners and circulating blower and its passageway in the appliance and venting system are kept clean. The appliance and its venting system should be inspected before use and at least annually by a qualified service person. More frequent cleaning may be required due to excessive lint from carpeting, bedding material, etc. The appliance area must be kept clear and free from combustible materials, gasoline and other flammable vapours and liquids.
- If the appliance shuts off, do not re-light until you provide fresh air. If appliance keeps shutting off, have it serviced. Keep burner and control compartment clean.
- Under no circumstances should this appliance be modified.
- Do not allow wind or fans to blow directly into the appliance. Avoid any drafts that alter burner flame patterns.



DANGER



HOT GLASS WILL CAUSE BURNS.

DO NOT TOUCH GLASS UNTIL COOLED.

NEVER ALLOW CHILDREN TO TOUCH GLASS.

A barrier designed to reduce the risk of burns from the hot viewing glass is provided with this appliance and must be installed for the protection of children and other at-risk individuals.

! WARNING

- Do not use a blower insert, heat exchanger insert or other accessory not approved for use with this appliance.
- This appliance must not be connected to a chimney flue pipe serving a separate solid fuel burning appliance.
- Do not use this appliance if any part has been under water. Immediately call a qualified service technician to inspect the appliance and to replace any part of the control system and any gas control which has been under water.
- Do not operate the appliance with the glass door (if equipped) removed, cracked or broken. Replacement of the glass should be done by a licensed or qualified service person.
- Do not strike or slam shut the appliance glass door, if equipped.
- **Only doors / optional fronts certified with the appliance are to be installed on the appliance.**
- Keep the packaging material out of reach of children and dispose of the material in a safe manner. As with all plastic bags, these are not toys and should be kept away from children and infants.
- Carbon or soot should not occur in a vent free appliance as it can distribute into the living area of your home. If you notice any signs of carbon or soot, immediately turn off your appliance and arrange to have it serviced by a qualified technician before operating it again.
- If equipped, the screen must be in place (closed) when the appliance is in operation.
- When equipped with pressure relief doors, they must be kept closed while the appliance is operating to prevent exhaust fumes containing carbon monoxide, from entering into the home. Temperatures of the exhaust escaping through these openings can also cause the surrounding combustible materials to overheat and catch fire.
- Carbon monoxide poisoning may lead to death; early signs of carbon monoxide poisoning resemble the flu, with headache, dizziness and/or nausea. If you have these signs, the appliance may not be working properly. Get fresh air at once! Have appliance serviced. Some people; pregnant women, persons with heart or lung disease, anemia, those under the influence of alcohol, those at high altitudes are more affected by carbon monoxide than others. Failure to keep the primary air opening(s) of the burner(s) clean may result in sooting and property damage.
- As with any combustion appliance, we recommend having your appliance regularly inspected and serviced as well as having a Carbon Monoxide Detector installed in the same area to defend you and your family against Carbon Monoxide (not applicable for outdoor appliances).
- Ensure clearances to combustibles are maintained when building a mantel or shelves above the appliance. Elevated temperatures on the wall or in the air above the appliance can cause melting, discolouration or damage to decorations, a TV or other electronic components.
- **For appliances equipped with a safety barrier; if the barrier becomes damaged, the barrier shall be replaced with the manufacturer's barrier for this appliance.**
- **Installation and repair should be done by a qualified service person. It is imperative that control compartments, burners and circulating air passageways of the appliance be kept clean.**
- For outdoor products only: this appliance must not be installed indoors or within any structure that prevents or inhibits the exhaust gases from dissipating in the outside atmosphere.
- If applicable, the millivolt version of this appliance uses and requires a fast acting thermocouple. Replace only with a fast acting thermocouple supplied by Wolf Steel Ltd.

! WARNING: This product can expose you to chemicals including lead and lead compounds, which are known to the State of California to cause cancer, and chemicals including carbon monoxide, which are known to the State of California to cause birth defects or other reproductive harm. For more information, go to www.P65Warnings.ca.gov.

WARNING

FIRE RISK HAZARD / DELAYED IGNITION

High supply pressure will damage the valve / controls.

Disconnect the appliance main gas valve/control from the supply piping when pressure testing that system at pressures in excess of 1/2 psi (3.5 kPa).

Isolate the appliance with it's shut off valve during any pressure testing of the supply piping at pressures equal to or less than 1/2 psi (3.5 kPa).

table of contents

1.0	general information	5	7.0	operation	33
1.1	rates and specifications	5	7.1	pilot-on-demand	34
1.2	installation checklist	6	8.0	finish framing	35
1.3	installation overview	7	8.1	flush	35
1.4	rating plate information	9	8.2	recessed	36
1.5	mobile home installation	9	9.0	finishing	37
1.6	EX36 dimensions	10	9.1	decorative panels	37
1.7	EX42 dimensions	11	9.2	log placement	37
1.8	hardware list	12	9.3	glowing embers	38
2.0	venting requirements	13	9.4	charcoal embers	38
2.1	typical venting installation	14	9.5	media placement	38
2.2	minimum air terminal location clearances	16	9.6	safety barrier & glass door installation / removal	39
2.3	all terminations	17	9.7	installing non-combustible board (non-DHM/DHC install)	40
3.0	rough framing	18	9.8	finishing flange adjustment	41
3.1	header shield installation	19	9.9	clearances around appliance	42
3.2	minimum framing dimensions	21	9.10	minimum combustible mantel clearances	43
3.3	minimum clearance to combustible enclosures	22	9.11	logo placement	43
4.0	venting installation	23	9.12	air shutter adjustment	44
4.1	horizontal installation	24	9.13	pilot burner adjustment	45
4.2	vertical installation	24	9.14	flame characteristics	45
4.3	using either flexible vent components	25	10.0	maintenance	46
4.3.1	horizontal air terminal installation	25	10.1	care of glass	46
4.3.2	vertical air terminal installation	26	10.2	annual maintenance	47
4.3.3	appliance vent connection	26	10.3	glass / door replacement	47
4.3.4	restricting vents	27	10.4	ember bed light replacement	48
5.0	electrical information	28	10.5	blower replacement	49
5.1	hard wiring connection	28	11.0	replacement parts	51
5.2	junction box installation	28	11.1	EX36 overview	52
5.3	electronic wiring diagram	28	11.2	EX36 valve train assembly	53
5.4	eFIRE Controller application	29	11.3	EX36 logs	54
5.5	initializing the transmitter / battery holder for the first time	30	11.4	EX42 overview	55
5.6	wiring diagram	31	11.5	EX42 valve train assembly	56
6.0	gas installation	32	11.6	EX42 logs	57
			12.0	troubleshooting	58
			13.0	warranty	61
			14.0	service history	62

note:

The information throughout this manual is believed to be correct at the time of printing. Wolf Steel Ltd. reserves the right to change or modify any information within this manual at any time without notice. Changes, other than editorial, are denoted by a vertical line in the margin.

Installer: please fill out appliance checklist in the Owner’s manual.

When the appliance is installed at elevations above 4,500ft (1372m), and in the absence of specific recommendations from the local authority having jurisdiction, the certified high altitude input rating shall be reduced at the rate of 4% for each additional 1,000ft (305m). Expansion / contraction noises during heating up and cooling down cycles are normal and are to be expected. Change in flame appearance from “HI” to “LO” is more evident in natural gas than in propane.

This appliance is approved for bathroom, bedroom and bed-sitting room installations and is certified for mobile home installation.

This appliance is only for use with the type of gas indicated on the rating plate. This appliance is not convertible for use with other gases, unless a certified kit is used.

note:

A barrier designed to reduce the risk of burns from the hot viewing glass is provided with the appliance and must be installed.

The protective wrap on plated parts is best removed when the assembly is at room temperature but this can be improved if the assembly is warmed, using a hair dryer or similar heat source.

This appliance is a decorative product. It is not a source of heat and not intended to burn solid fuel.



Batteries must be disposed of according to the local laws and regulations. Some batteries may be recycled, and may be accepted for disposal at your local recycling center. Check with your municipality for recycling instructions.

1.1 rates and specifications

	EX36		EX42	
Fuel Type	Natural Gas	Propane	Natural Gas	Propane
Altitude (FT)	0-4,500			
Max. Input (BTU/hr)	37,000	34,000	45,000	39,000
Min. Inlet Gas Supply Pressure	4.5” w.c. (11mb)	11” w.c. (27mb)	4.5” w.c. (11mb)	11” w.c. (27mb)
Max. Inlet Gas Supply Pressure	7”* w.c. (17mb)	13” w.c. (32mb)	7”* w.c. (17mb)	13” w.c. (32mb)
Manifold Pressure (Under Flow Conditions)	3.5” w.c. (9mb)	10” w.c. (25mb)	3.5” w.c. (9mb)	10” w.c. (25mb)

*Maximum inlet pressure not to exceed 13”.

This appliance is suitable for use with Napoleon’s optional Ducted Heat Management (DHM), Dynamic Heat Control™ (DHC) & Dynamic Heat Control™ Plus (DHC+) systems. THIS MANUAL **DOES NOT** include detailed information relating to these optional systems. Framing and finishing are **NOT** the same. For further details, refer to the Ducted Heat Management (DHM) or Dynamic Heat Control™ (DHC) installation manual provided with the kit before starting installation.

general information

1.2 installation checklist

GAS FIREPLACE INSTALLATION CHECKLIST

Customer: _____ Date Installed: _____
 Address: _____ Installer: _____
 Model: _____ Dealer: _____
 Serial #: _____ Dealer Phone #: _____

This checklist is a reference tool only. It is not intended as a substitute for the installation instructions.

Fireplace Installation

	YES	<u>IF NOT, PLEASE EXPLAIN WHY?</u>
Is the fireplace level and secured?	<input type="checkbox"/>	_____
Are the factory supplied non-combustible materials installed?	<input type="checkbox"/>	_____
Is the exterior wall insulated and dry-walled?	<input type="checkbox"/>	_____
Are the clearances to combustibles maintained?	<input type="checkbox"/>	_____
Are the logs/media installed as instructed?	<input type="checkbox"/>	_____
Are the accessories installed as instructed?	<input type="checkbox"/>	_____
Is the glass door properly sealed and unobstructed?	<input type="checkbox"/>	_____
Is the safety barrier installed and secure?	<input type="checkbox"/>	_____
Are all required accessories installed (i.e. door trims)?	<input type="checkbox"/>	_____

Venting Installation

Is the venting configuration within the parameters?	<input type="checkbox"/>	_____
Has the venting been sealed with the appropriate sealant?	<input type="checkbox"/>	_____
Is the venting supported and secured?	<input type="checkbox"/>	_____
Are all clearances to combustibles maintained?	<input type="checkbox"/>	_____
Are the appropriate firestops and shields properly installed?	<input type="checkbox"/>	_____
Is the terminal, level, secured and sealed?	<input type="checkbox"/>	_____

Gas and Electrical

Was the fireplace converted to propane? If yes, does the fireplace have a power vent?	<input type="checkbox"/>	_____
Was the appropriate supply pressure verified?	<input type="checkbox"/>	_____
Were all gas connections leak tested?	<input type="checkbox"/>	_____
Is the 110 VAC supply connection to the fireplace compliant?	<input type="checkbox"/>	_____
Are all electrical wires protected from damage?	<input type="checkbox"/>	_____

Finishing

Non-combustible materials used as per instructions?	<input type="checkbox"/>	_____
Enclosure instructions forwarded to builder/finisher?	<input type="checkbox"/>	_____
Minimum enclosure dimensions compliant?	<input type="checkbox"/>	_____
Combustible Mantel Clearances compliant?	<input type="checkbox"/>	_____

Commissioning

Was the fireplace test fired and all operation verified?	<input type="checkbox"/>	_____
Safety and lighting instructions reviewed with the Customer?	<input type="checkbox"/>	_____
Operating Instruction Manual left with the Customer?	<input type="checkbox"/>	_____

Wolf Steel Ltd. recommends photographs of the various stages of construction be filed along with a copy of this completed form.

1.3 installation overview

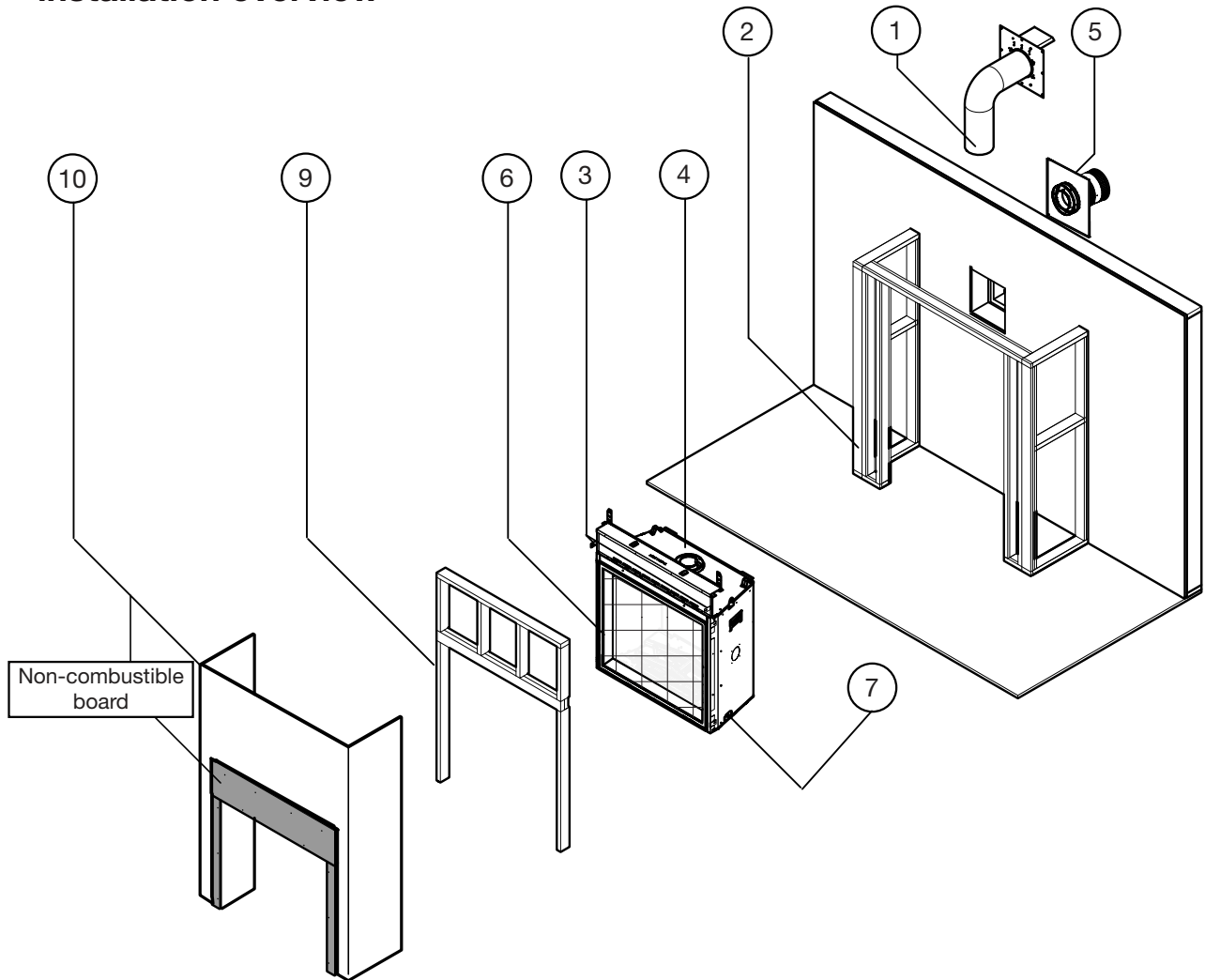

Recommended installation steps:

1. Determine venting requirements before deciding the final location of the appliance.
2. Determine finished floor thickness (see “rough framing” section).
- 3. Plan out appliance enclosure, framing, fronts, accessories, etc.**
4. Install rough framing (refer to “rough framing” section).
5. Install nailing tabs and header shield (refer to “header shield installation” sections).
6. Place the appliance in its final position.
7. Install appliance venting (refer to “venting installation” section).
8. Install all electrical wirings (refer to “electrical information” section).
9. Install gas lines (refer to “gas installation” section).
10. Test appliance.
11. Complete framing (refer to “finish framing - typical” **or** “finish framing - recess” sections).
12. Finishing (refer to “finishing” section).
13. Complete checklist in the owner’s manual and apply serial number to owner’s manual.

note:

For Dynamic Heat Control™ (DHC) or Ducted Heat Mangement (DHM) installation steps, refer to the leaflet provided with the DHC/DHM kit. Start DHC/DHM installation before step 3 (place the appliance in its final position).

WARNING

- Always light the pilot whether for the first time or if the gas supply has run out, with the glass door opened or removed.
- Provide adequate clearance for servicing and operating the appliance.
- Provide adequate ventilation.
- Never obstruct the front opening of the appliance.
- Objects placed in front of the appliance must be kept a minimum of 48" (121.9cm) from the front face of the appliance.
- Surfaces around and especially above the appliance can become hot. Avoid contact when appliance is operating.
- Fire risk. Explosion hazard.
- High pressure will damage valve. Disconnect gas supply piping before pressure testing gas line at test pressures above 1/2 PISG (35mb). Close the manual shut-off valve before pressure testing gas line at test pressures equal to or less than 1/2 PISG (35mb).
- Use only Wolf Steel approved optional accessories and replacement parts with this appliance using non-listed accessories (blowers, doors, louvres, trims, gas components, venting components, etc.) could result in a safety hazard and will void the warranty and certification.
- The appliance must not be operated at temperatures below freezing (32°F/0°C). Allow the appliance to warm to above freezing prior to operation.

THIS GAS APPLIANCE MUST BE INSTALLED AND SERVICED BY A QUALIFIED INSTALLER to conform with local codes. Installation practices vary from region to region and it is important to know the specifics that apply to your area, for example in the state of Massachusetts:

- This product must be installed by a licensed plumber or gas fitter when installed within the commonwealth of Massachusetts.
- The appliance damper must be removed or welded in the open position prior to installation of an appliance insert or gas log.
- The appliance off valve must be a "T" handle gas cock.
- The flexible connector must not be longer than 36 inches (0.9m).
- A carbon monoxide detector is required in all rooms containing gas fired appliances.
- The appliance is not approved for installation in a bedroom or bathroom unless the unit is a direct vent sealed combustion product.

The installation must conform with local codes or, in absence of local codes, the National Gas and Propane Installation Code CSA B149.1 in Canada, or the National Fuel Gas Code, ANSI Z223.1 / NFPA 54 in the United States. Suitable for mobile home installation if installed in accordance with the current standard CAN/CSA Z240MH Series, for gas equipped mobile homes, in Canada or ANSI Z223.1 and NFPA 54 in the United States.

The appliance and its individual shutoff valve must be disconnected from the gas supply piping system during any pressure testing of that system at test pressures in excess of 1/2 psig (35 mb).

The appliance must be isolated from the gas supply piping system by closing its individual manual shutoff valve during any pressure testing of the gas supply piping system at test pressures equal to or less than 1/2 psig (35 mb). When installed with a blower or fan, the junction box must be electrically connected and grounded in accordance with local codes. In the absence of local codes, use the current CSA C22.1 Canadian Electrical Code in Canada or the ANSI / NFPA 70 National Electric Code in the United States. In the case where the blower is equipped with a power cord, it must be connected into a properly grounded receptacle. The grounding prong must not be removed from the cord plug.

The following does not apply to inserts; as long as the required clearance to combustibles is maintained, the most desirable and beneficial location for an appliance is in the center of a building, thereby allowing the most efficient use of the heat created. The location of windows, doors and, the traffic flow in the room where the appliance is to be located should be considered. If possible, you should choose a location where the vent will pass through the house without cutting a floor or roof joist. If the appliance is installed directly on carpeting, vinyl tile or other combustible material other than wood flooring, the appliance shall be installed on a metal or wood panel extending the full width and depth, unless otherwise tested.



We suggest that our gas hearth products be installed and serviced by professionals who are certified in the U.S. by the National Fireplace Institute® (NFI) as NFI Gas Specialists

1.4 rating plate information

This illustration is for reference only. Refer to the rating plate on the appliance for accurate information.

Certified to Canadian and American National Standards: **CSA 2.22-XXXX / ANSI Z21.50-XXXX for Vented Decorative Gas Appliances**
 Certifié selon les normes Nationales Canadiennes et Américaines: **CSA 2.22-XXXX / ANSI Z21.50-XXXX pour les Appareils à gaz décoratif à évacuation**

Direct vent, vented gas fireplaces. Approved for bedroom, bathroom and bed-sitting room installation. Suitable for mobile home installation, if installed in accordance with the current standard CAN / CSA Z240MH Series gas equipped mobile homes in Canada, or, in the United States, the *Manufactured Home Construction and Safety Standard, Title 24 CFR, Part 3280*. When this US Standard is not applicable, use the *Standard for Fire Safety Criteria for Manufactured Home Installations, Sites and Communities, ANSI/NFPA 501A*. This appliance must be installed in accordance with local codes, if any; if none, follow the current ANSI Z223.1 or CSA B149. **For use with barrier WXXX-XXXX. Follow installation instructions.**
 Foyer à gaz ventilé. Homologué pour installation dans une chambre à coucher, une salle de bain et un studio. Approuvé pour installation dans une maison mobile si son installation conforme aux exigences de la norme CAN / CSA Z240MH Série de maisons mobile équipées au gaz en vigueur au Canada, ou, aux États-Unis selon la norme *24 CFR, Part 3280, Manufactured Home Construction and Safety Standard*. Dans le cas où cette norme d'États-Unis n'est pas pertinente, utiliser la norme *NFPA 501A, Fire Safety Criteria for Manufactured Home Installations, Sites and Communities*. Installer l'appareil selon les codes ou règlements locaux ou, en l'absence de tels règlements, selon les codes d'installation ANSI Z223.1 ou CSA B149 en vigueur. **Utiliser uniquement avec l'écran WXXX-XXXX. Suivre les instructions d'installation.**



REFERENCE# 161746

VENTED DECORATIVE GAS APPLIANCE: NOT A SOURCE OF HEAT, NOT INTENDED FOR USE AS A HEATING APPLIANCE, NOT FOR USE WITH SOLID FUEL.
APPAREIL À GAZ DÉCORATIF À ÉVACUATION: N'EST PAS UNE SOURCE DE CHALEUR; N'EST PAS DESTINÉ À ÊTRE UTILISÉ COMME UN APPAREIL DE CHAUFFAGE; NE CONVIENT PAS AUX COMBUSTIBLES SOLIDES.

FOR USE WITH GLASS DOORS CERTIFIED WITH THIS APPLIANCE ONLY. POUR UTILISATION UNIQUEMENT AVEC LES PORTES EN VERRE CERTIFIÉES AVEC L'APPAREIL.

WARNING: Do not add any material to the appliance which will come in contact with the flames, other than that supplied by the manufacturer with the appliance.
AVERTISSEMENT: N'ajoutez pas à cet appareil aucun matériau matériel devant entretenir contact avec les flammes autre que celui qui est fourni avec cet appareil par le fabricant. The appliance must be vented using the appropriate Napoleon vent kits. See installation manual for venting specifications. Proper reinstallation and resealing is necessary after servicing the vent-air intake system. L'appareil doit être ventilé à l'aide de l'ensemble d'évacuation propre à Napoleon. Référez au manuel d'installation pour les spécifications d'évacuation. Il est nécessaire de bien réinstaller et resceller l'évacuation après avoir exécuté l'entretien du système de prise d'air.

Serial Number / N° de Série: XXXX **W385-XXXX**

MODEL / MODÈLE
 9700539 (WSL) 4001658 (NAC) 4001657 (NGZ) 4001659 (WUSA)

Altitude Input
 XXXX XXXX XXXX XXXX
 XXXX XXXX XXXX XXXX

Reduced Input P4
 XX,XXX XX,XXX XX,XXX
 XX.X% XX.X% XX.X%

Manifold Pressure: 3.5" w.c. (NG) **Manifold Pressure:** 10" w.c. (P)
Minimum Supply Pressure: 4.5" w.c. (NG) **Minimum Supply Pressure:** 11" w.c. (P)
Maximum Supply Pressure: 7" w.c. (NG) **Maximum Supply Pressure:** 13" w.c. (P)

Pression au Collecteur: 3,5" d'une colonne d'eau (GN) **Pression au Collecteur:** 10" d'une colonne d'eau (P)
Pression d'Alimentation Min: 4,5" d'une colonne d'eau (GN) **Pression d'Alimentation Min:** 11" d'une colonne d'eau (P)
Pression d'Alimentation Max: 7" d'une colonne d'eau (GN) **Pression d'Alimentation Max:** 13" d'une colonne d'eau (P)

Minimum clearance to combustible materials: Dessus, côtés et arrière: selon les espaces de dégagements pour les matériaux d'ossature selon le manuel du propriétaire pour les matériaux de finition.
 Top X" Dessus X"
 Floor X" Plancher X"
 Sides X" Côtés X"
 Back X" Arrière X"
 Vent top X" Dessus du conduit d'évent X"
 Vent sides & bottom X" Côtés et dessous du conduit d'évent X"
 Recessed depth X" Profondeur d'encastrement face X"
 *** Mantel X" from appliance opening *** Tablette X" de l'ouverture de l'appareil
 *** Maximum horizontal extension: *** L'extension horizontale maximale X".
 X". See installation manual for greater extensions, minimum vent lengths and maximum vent lengths. Référez au manuel d'installation pour des extensions plus grandes, les longueurs d'évacuation minimales et maximales.
 Electrical rating: 115V, 60Hz. Less than 12 amperes. Spécifications électriques: 115V, 60Hz. Moins de 12 ampères.

WOLF STEEL LTD. 24 Napoleon Road, Barrie, ON, L4M 0G8 Canada

note:
 The rating plate must remain with the appliance at all times. It must not be removed.

1.5 mobile home installation

This appliance must be installed in accordance with the manufacturer's instructions and the Manufactured Home Construction and Safety Standard, Title 24 CFR, Part 3280, in the United States or the Mobile Home Standard, CAN/CSA Z240 MH Series, in Canada. This appliance is only for use with the type(s) of gas indicated on the rating plate.

This mobile/manufactured home listed appliance comes factory equipped with a means to secure the appliance. Built in appliances are equipped with 1/4" (6.4mm) diameter holes located in the front left and right corners of the base. Use appropriate fasteners, inserted through the holes in the base to secure. For free standing products contact your local authorized dealer / distributor for the appropriate securing kit. For mobile home installations, the appliance must be fastened in place. It is recommended that the appliance be secured in all installations. Always turn off the pilot and the fuel supply at the source, prior to moving the mobile home. After moving the mobile home and prior to lighting the appliance, ensure that the logs are positioned correctly.

This appliance is certified to be installed in an aftermarket permanently located, manufactured (mobile) home, where not prohibited by local codes. This appliance is only for use with the type of gas indicated on the rating plate. This appliance is not convertible for use with other gases, unless a certified kit is used.

Conversion Kits
 This appliance is field convertible between Natural Gas (NG) and Propane (P). To convert from one gas to another, consult your Authorized dealer/distributor.

general information

1.6 EX36 dimensions

EX36

TOP VIEW

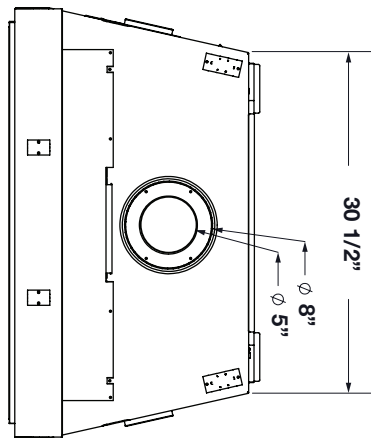

FRONT VIEW

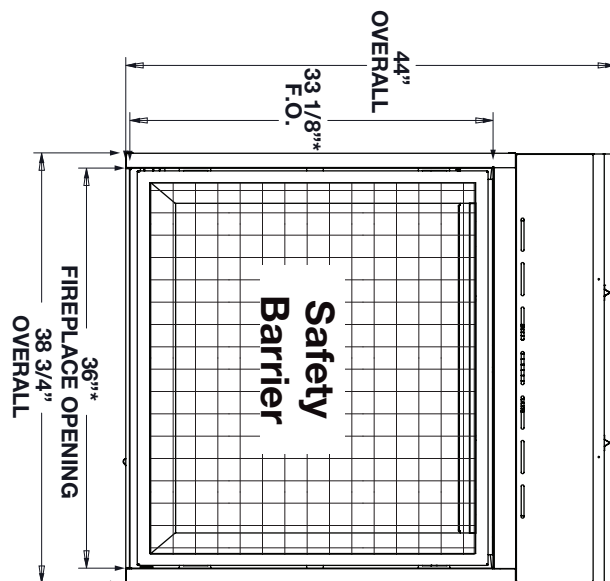

RIGHT SIDE VIEW

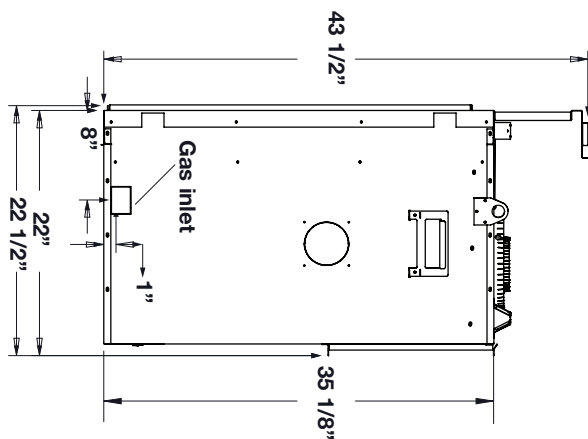

* Finishing flange (the finishing flange defines the perimeter of the fireplace opening. Framing or finishing materials must **NEVER** encroach inside the finishing flange).

1.7 EX42 dimensions

EX42

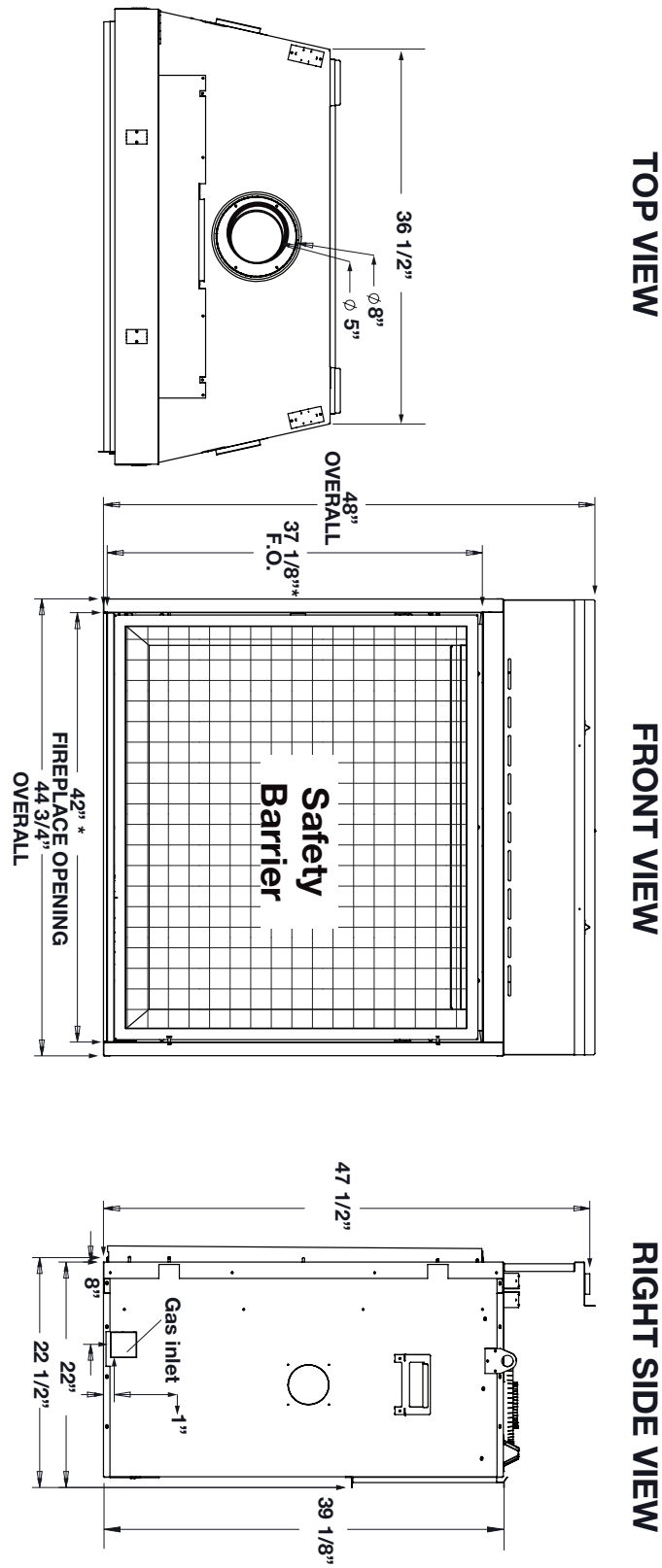

* Finishing flange (the finishing flange defines the perimeter of the fireplace opening. Framing or finishing materials must **NEVER** encroach inside the finishing flange).

1.8 hardware list

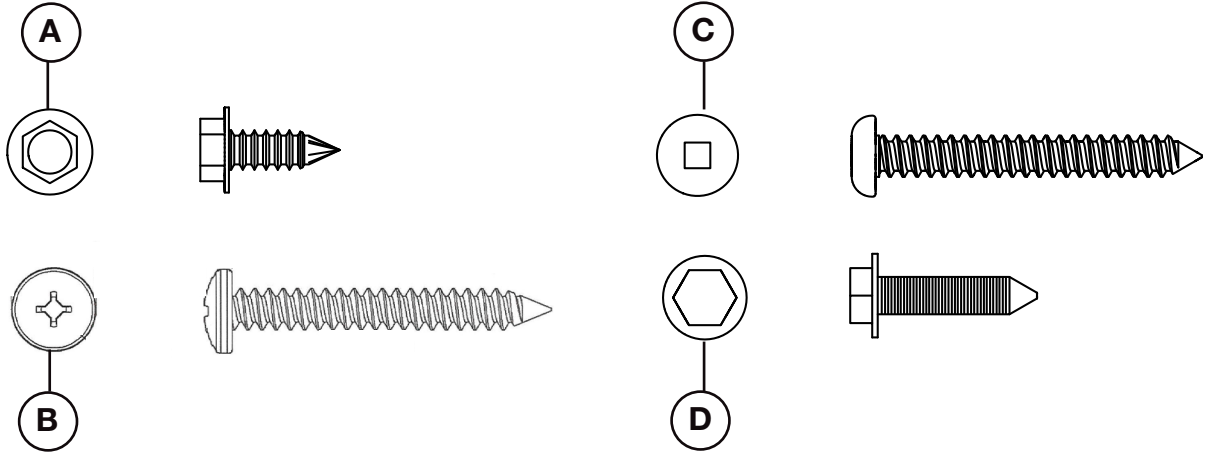

Ref. #	Description	Quantity
A	#9-14 x 1/2" Wildrill 1/4" Hex	25
B	#10 x 2 1/2" Pan Head	4
C	#10 x 1 1/2" Truss Head	4
D	#8 x 3/4" Hex Head (Blk Zinc)	4

note:

Only fasteners supplied with the appliance will be illustrated.

! WARNING

- Risk of fire. Maintain specified air space clearances to vent pipe and appliance.
- The vent system must be supported every 3' (0.9m) for both vertical and horizontal runs. Use support ring assembly W010-0067 or equivalent non-combustible strapping to maintain the minimum clearance to combustibles for both vertical and horizontal runs. Spacers are attached to the inner pipe at predetermined intervals to maintain an even air gap to the outer pipe. This gap is required for safe operation. A spacer is required at the start, middle, and end of each elbow to ensure this gap is maintained. These spaces must not be removed.

This appliance uses a 5" (127mm) exhaust / 8" (203.2mm) air intake vent pipe system. Refer to the section applicable to your installation.

For safe and proper operation of the appliance follow the venting instructions exactly. Deviation from the minimum vertical vent length can create difficulty in burner start-up and/or carboning. Under extreme vent configurations, allow several minutes (5-15) for the flame to stabilize after ignition. Although not a requirement, it is recommended for vent lengths that pass through unheated spaces (attics, garages, crawl spaces) be insulated with the insulation wrapped in a protective sleeve to minimize condensation. Provide a means for visually checking the vent connection to the appliance after the appliance is installed. Use a firestop, vent pipe shield or attic insulation shield when penetrating interior walls, floor or ceiling.

The vent terminal may be painted with a high temperature paint to match exterior colours. Use an outdoor paint suitable for 400°F (200°C). Application and performance of paint is the consumer's responsibility. Spot testing is recommended.

note:

If for any reason the vent air intake system is disassembled; reinstall per the instructions provided for the initial installation.

This appliance must be installed with a continuous connection of exhaust and air intake vent pipes. Utilizing alternate constructions, such as a chimney as part of the vent system, is not permitted.

Use only Wolf Steel, Metal-Fab, BDM, Simpson Dura-Vent, or Selkirk Direct Temp venting components. Minimum and maximum vent lengths, for both horizontal and vertical installations, clearances from vent pipes to combustibles and air terminal locations as set out in this manual apply to all vent systems and must be adhered to. For Metal-Fab, BDM, Simpson Dura-Vent, or Selkirk Direct Temp, follow the installation procedure provided with the venting components or on the website for your venting supplier.

A starter adaptor must be used with the following vent systems and may be purchased through Wolf Steel or from the corresponding supplier listed below:

Venting System	Manufacturer	Starter Adapter Part Number	Supplier	Website
SureSeal	Metal-Fab	5NDA	Wolf Steel	www.mtfab.com
Direct Vent Pro	Simpson DuraVent	W175-0170	Wolf Steel	www.duravent.com
Pro-Form	BDM	N/A	BDM	www.dalsinmfg.com
Direct Temp	Selkirk	5DT-AAN	Selkirk	www.selkirkcorp.com
Ventis	Olympia Chimney and Venting	VDV-NA05-58F	Olympia Chimney and Venting	www.olympiachimney.com

Connections made by means of an adaptor at the appliance, as well as the connection at the vent terminal must be sealed. RTV sealant may be used on both the inner exhaust and outer intake vent pipe joints of all other approved vent systems, except for the exhaust vent pipe connection to the appliance flue collar which must be sealed using the black high temperature sealant Mill Pac.

For all vent systems is strongly recommend for all installations but required when power venting the appliance, that the outer air intake joints are sealed using either high temperature silicone (RTV) or a suitable aluminum tape that covers each joint in the vent system entirely around its circumference. This will ensure the best performance in every application and avoids performance or condensation concerns that may occur in "tightly" constructed homes, particularly those in cold climates.

When using Wolf Steel venting components, use only approved Wolf Steel rigid / flexible components with the following termination kits: wall terminal kit **GD422R-2** or **ST58U-1**, or 1/12 to 7/12 pitch roof terminal kit **GD410**, 8/12 to 12/12 roof terminal kit **GD411**, flat roof terminal kit **GD412** or periscope kit **GD401** (for wall penetration below grade). With flexible venting, in conjunction with the various terminations, use either the 5 foot (1.5m) vent kit **GD420** or the 10 foot (3.1m) vent kit **GD430**.

venting requirements

For optimum flame appearance and appliance performance, keep the vent length and number of elbows to a minimum.

The air terminal must remain unobstructed at all times. Examine the air terminal at least once a year to verify that it is unobstructed and undamaged.

Rigid and flexible venting systems must not be combined. Different venting manufacturer components must not be combined.

These vent kits allow for either horizontal or vertical venting of the appliance. The maximum allowable horizontal run is 20 feet (6.1 m). The maximum allowable vertical vent length is 40 feet (12.2m). The maximum number of vent connections is two horizontally or three vertically (excluding the appliance and the air terminal connections) when using flexible venting.

Horizontal runs may have a 0" (0mm) rise per foot/meter however for optimum performance it is recommended that all horizontal runs have a minimum 1/4" (21mm) rise per foot/meter using flexible venting. For safe and proper operation of the appliance, follow the venting instructions exactly.

A terminal shall not terminate directly above a sidewalk or paved driveway which is located between two single family dwellings and serves both dwellings. Local codes or regulations may require different clearances.

This appliance is certified for use with a power vent kit. Contact your local authorized dealer for more information.

All vent measurements start at the base of the air collar of the appliance.

2.1 typical venting installation

! WARNING

- The first 3 feet (0.9m) of outer 8" (203mm) diameter vent pipe from the appliance must be wrapped in the 1" (25mm) thick insulation sleeve (supplied).

	EX36	EX42
A	59" (1499mm)	63" (1600mm)

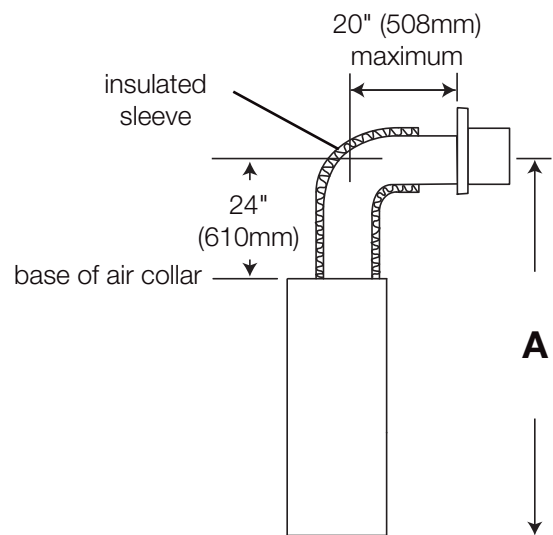

Use the periscope kit to locate the air termination above grade. The periscope must be installed so that when final grading is completed, the bottom air slot is located a minimum 12" (30.5cm) above grade. The maximum allowable vent length is 10' (3m) for a fireplace and 8' (2m) for a stove.

! WARNING

- The first 3 feet (0.9m) of outer 8" (203mm) diameter vent pipe from the appliance must be wrapped in the 1" (25mm) thick insulation sleeve (supplied).

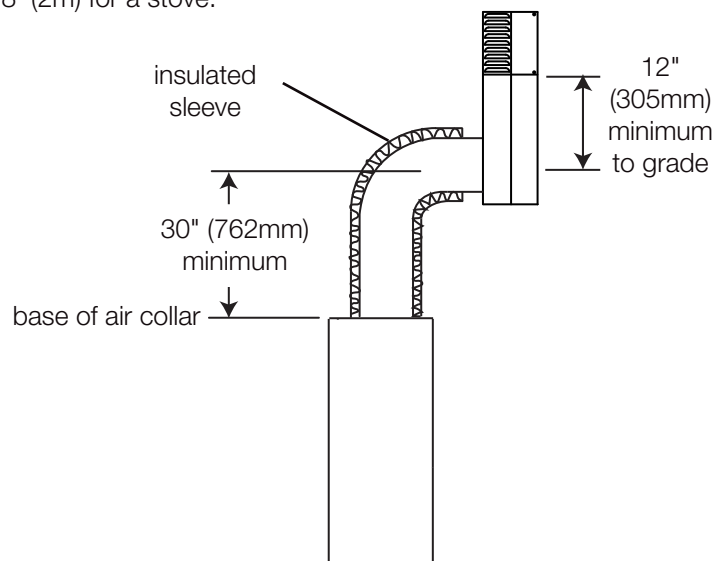

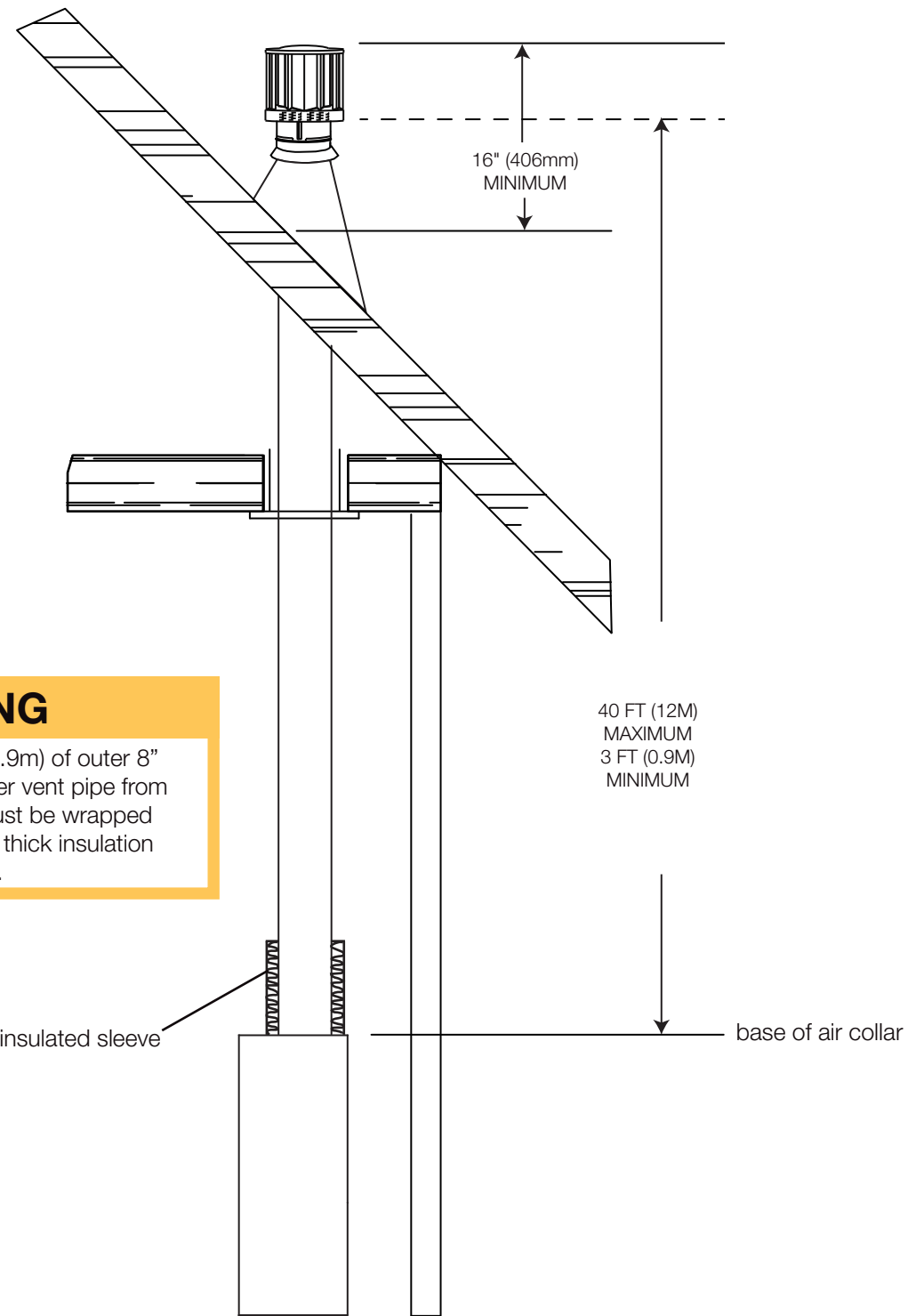

! WARNING

- The first 3 feet (0.9m) of outer 8" (203mm) diameter vent pipe from the appliance must be wrapped in the 1" (25mm) thick insulation sleeve (supplied).

* Refer to "venting requirements" and "venting installation" sections.

venting requirements

2.2 minimum air terminal location clearances

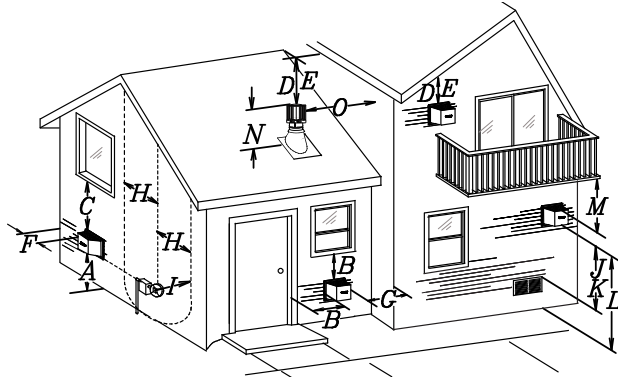

Covered balcony applications ††*

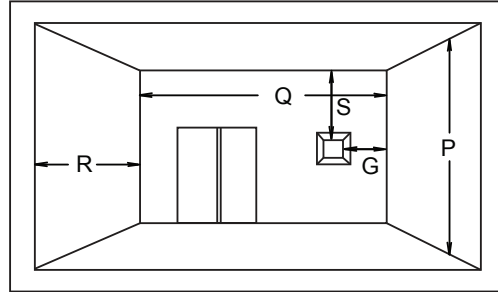

$Q_{MIN} = 3 \text{ feet}$ (0.9m)	$R_{MAX} = 2 \times Q_{ACTUAL}$	$R_{MAX} \leq 15 \text{ feet}$ (4.6m)
--------------------------------------	---------------------------------	--

	INSTALLATIONS		note:
	CANADA	U.S.A.	
A	12" (30.5cm)	12" (30.5cm)	Clearance above grade, veranda porch, deck or balcony.
B	12" (30.5cm) ^Δ	9" (229mm) ^Δ	Clearance to windows or doors that open.
C	12" (30.5cm)*	12" (30.5cm)*	Clearance to permanently closed windows.
D	18" (45.7cm)**	18" (45.7cm)**	Vertical clearance to ventilated soffits located above the terminal within a horizontal distance of 2' (0.6m) from the center line of the terminal.
E	12" (30.5cm)**	12" (30.5cm)**	Clearance to unventilated soffit.
F	0" (0mm)	0" (0mm)	Clearance to an outside corner wall.
G	0" (0mm)***	0" (0mm)***	Clearance to an inside non -combustible corner wall or protruding non -combustible obstructions (chimney, etc.).
	2" (51mm)***	2" (51mm)***	Clearance to an inside combustible corner wall or protruding combustible obstructions (vent chase, etc.).
H	3'(0.9m)	3'(0.9m)****	Clearance to each side of the center line extended above the meter / regulator assembly to a maximum vertical distance of 15' (4.6m).
I	3' (0.9m)	3' (0.9m)****	Clearance to a service regulator vent outlet.
J	12" (30.5cm)	9" (229mm)	Clearance to a non-mechanical air supply inlet to the building or a combustion air inlet to any other appliance.
K	6' (1.8m)	3' (0.9m) †	Clearance to a mechanical air supply inlet.
L	7' (2.1m) ‡	7' (2.1m) ****	Clearance above a paved sidewalk or paved driveway located on public property.
M	12" (30.5cm)††	12" (30.5cm)****	Clearance under a veranda, porch, deck or overhang.
N	16" (40.6cm)	16" (40.6cm)	Clearance above the roof.
O	2' (0.6m)†*	2' (0.6m) †*	Clearance from an adjacent wall including neighbouring buildings.
P	8' (2.4m)	8' (2.4m)	Roof must be non -combustible without openings.
Q	3' (0.9m)	3' (0.9m)	See chart for wider wall dimensions.
R	6' (1.8m)	6' (1.8m)	See chart for deeper wall dimensions. The terminal shall not be installed on any wall that has an opening between the terminal and the open side of the structure.
S	12" (30.5cm)	12" (30.5cm)	Clearance under a covered balcony

Δ The terminal shall not be located less than 6 feet under a window that opens on a horizontal plane in a structure with three walls and a roof.

* Recommended to prevent condensation on windows and thermal breakage

** It is recommended to use a heat shield and to maximize the distance to vinyl clad soffits.

*** The periscope requires a minimum 18 inches clearance from an inside corner.

**** This is a recommended distance. For additional requirements, check local codes.

† 3 feet above if within 10 feet horizontally.

‡ A vent shall not terminate where it may cause hazardous frost or ice accumulations on adjacent property surfaces.

†† Permitted only if the veranda, porch, or deck is fully open on a minimum of two sides beneath the floor.

†* Recommended to prevent recirculation of exhaust products. For additional requirements, check local codes.

††* Permitted only if the balcony is fully open on a minimum of one side.

note:

Clearances are to be in accordance with local installation codes and the requirements of the gas supplier. In their absence, clearances are to be as listed above and are based on national codes.

2.3 all terminations

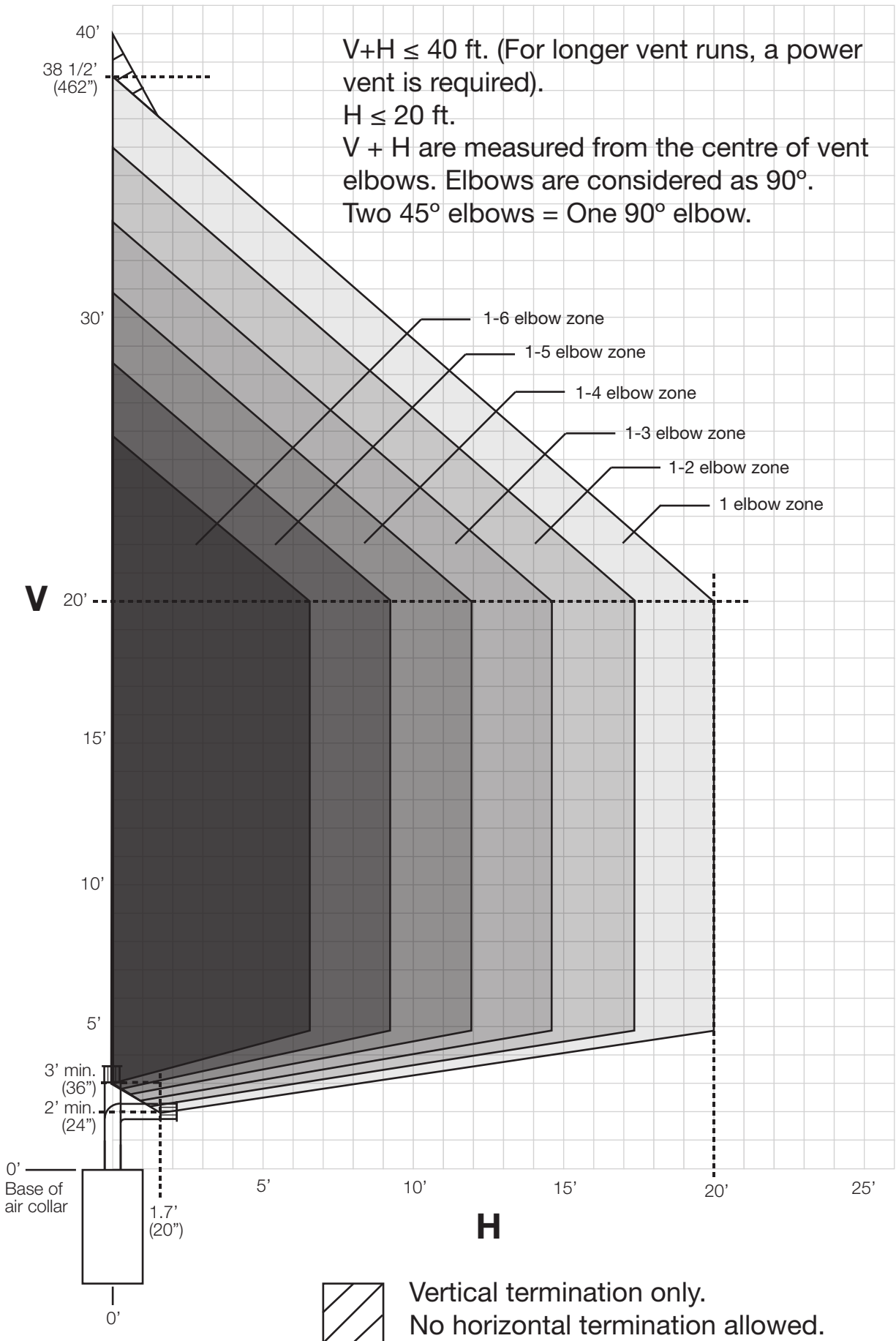

3.0 rough framing

note:

When using optional finishing accessories, the framing dimensions and finishing materials may differ from what is outlined in the section below; refer to the leaflet instructions supplied in the accessory kit for specific framing and finishing specifications.

WARNING

- Risk of fire!
- In order to avoid the possibility of exposed insulation or vapour barrier coming in contact with the appliance body, it is recommended that the walls of the appliance enclosure be “finished” (i.e. drywall / sheetrock), as you would finish any other outside wall of a home. This will ensure that clearance to combustibles is maintained within the cavity.
- Do not notch the framing around the appliance stand offs. Failure to maintain air space clearance may cause over heating and fire. Prevent contact with sagging or loose insulation or framing and other combustible materials. Block opening into the chase to prevent entry of blown-in insulation. Make sure insulation and other materials are secured.
- When constructing the enclosure, allow for finishing material thickness to maintain clearances. Framing or finishing material closer than the minimums listed must be constructed entirely of non-combustible materials. Materials consisting entirely of steel, iron, brick, tile, concrete, slate, glass or plasters, or any combination thereof are suitable. Materials that are reported as passing ASTM E136, standard test method for behaviour of materials in a vertical tube furnace at 1382°F (750°C) and UL763 shall be considered non-combustible materials.
- Minimum clearance to combustibles must be maintained or a serious fire hazard could result.
- The appliance requires a minimum enclosure height. Measure from the appliance base.
- If steel stud framing kits with cement board are provided, or specified in the installation instructions, they must be installed.
- If specified in the installation instruction, finishing must be done using a non-combustible board, ceramic tile, marble, etc. Do **NOT** use wood or drywall. Any fire rated drywall is **not** acceptable.

note:

It is NOT necessary to install a hearth extension, but the appliance MUST be raised to be flush with either the hearth or the finished floor if installing any optional trims.

note:

It is necessary early on to choose either a non-combustible finishing kit (NCEX36/42) or a combustible finishing kit (DHCEX/DHMEX). Specific framing requirements need to be considered depending on which kit is used. With the combustible framing kit (DHCEX/DHMEX), an air outlet opening is required in the appliance enclosure, as opposed to the non-combustible framing kit (NCEX36/42) where no opening is needed. Refer to the manual or leaflet for details.

3.1 header shield installation

note:

The header shield provides the minimum clearance to the header. Use only non-combustible material for the width of the appliance.

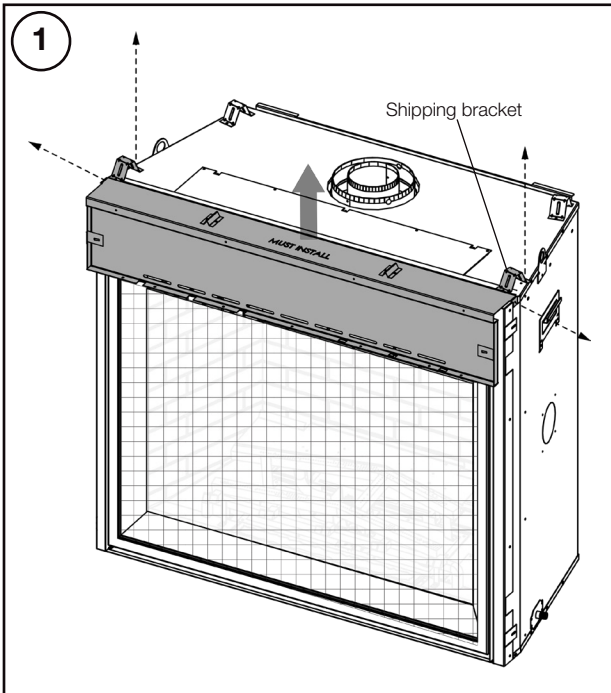

Remove the 4 screws securing the header shield.

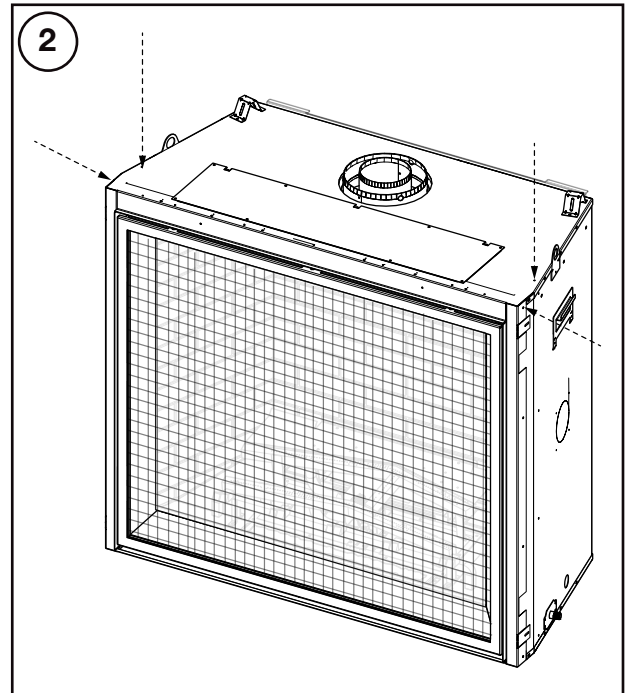

Once the header shield is removed, replace the 4 screws removed in step 1.

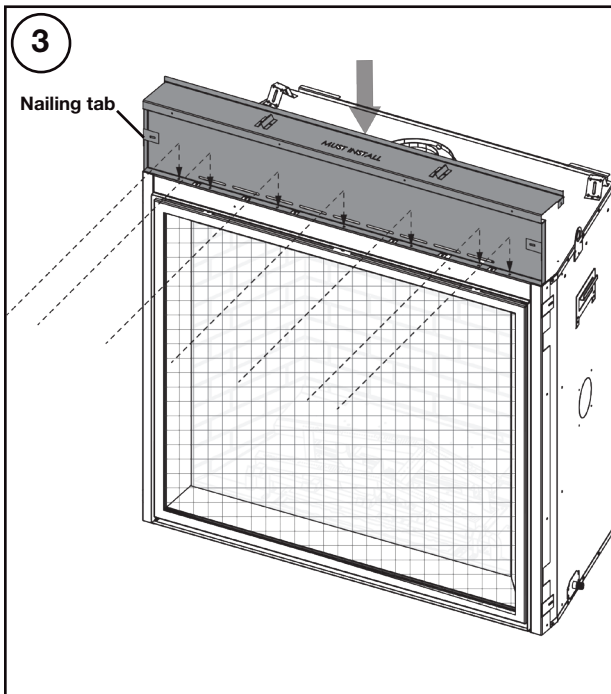

Secure the header shield with 7 screws (provided) and remove the shipping brackets.

note:

Screw count varies by model.

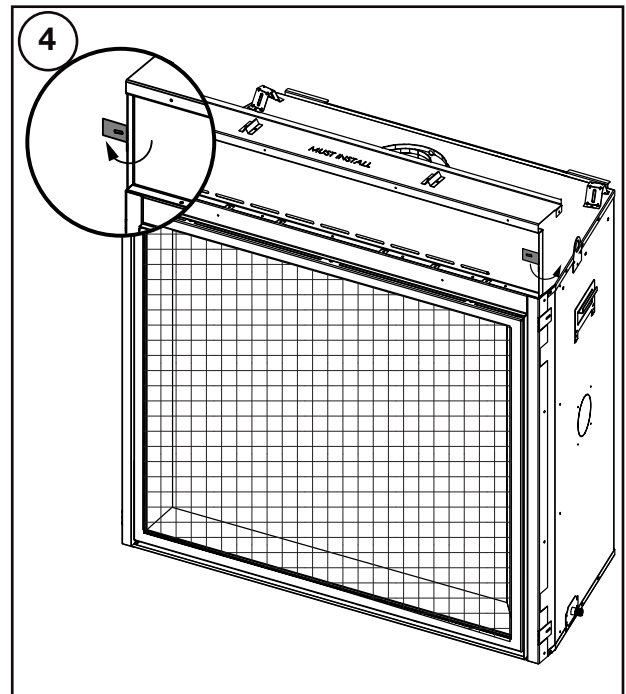

Bend the nailing tabs out 180°.

rough framing

note:

For heavier finishing materials such as marble, we recommend adding extra support to the frame. Ensure there is adequate floor support for the appliance and finishing material.

Before framing your appliance, determine vent requirements prior to deciding the final location of the appliance. After rough framing, place the appliance in its final position.

Finished floor thicknesses vary. Lift the appliance the thickness of the floor material - this ensures the 1/4" clearance when the finishing trim is installed (i.e. 1/4" underlay with 1/4" tile will require a 1/2" finished floor thickness. Lift the appliance using 1/2" plywood).

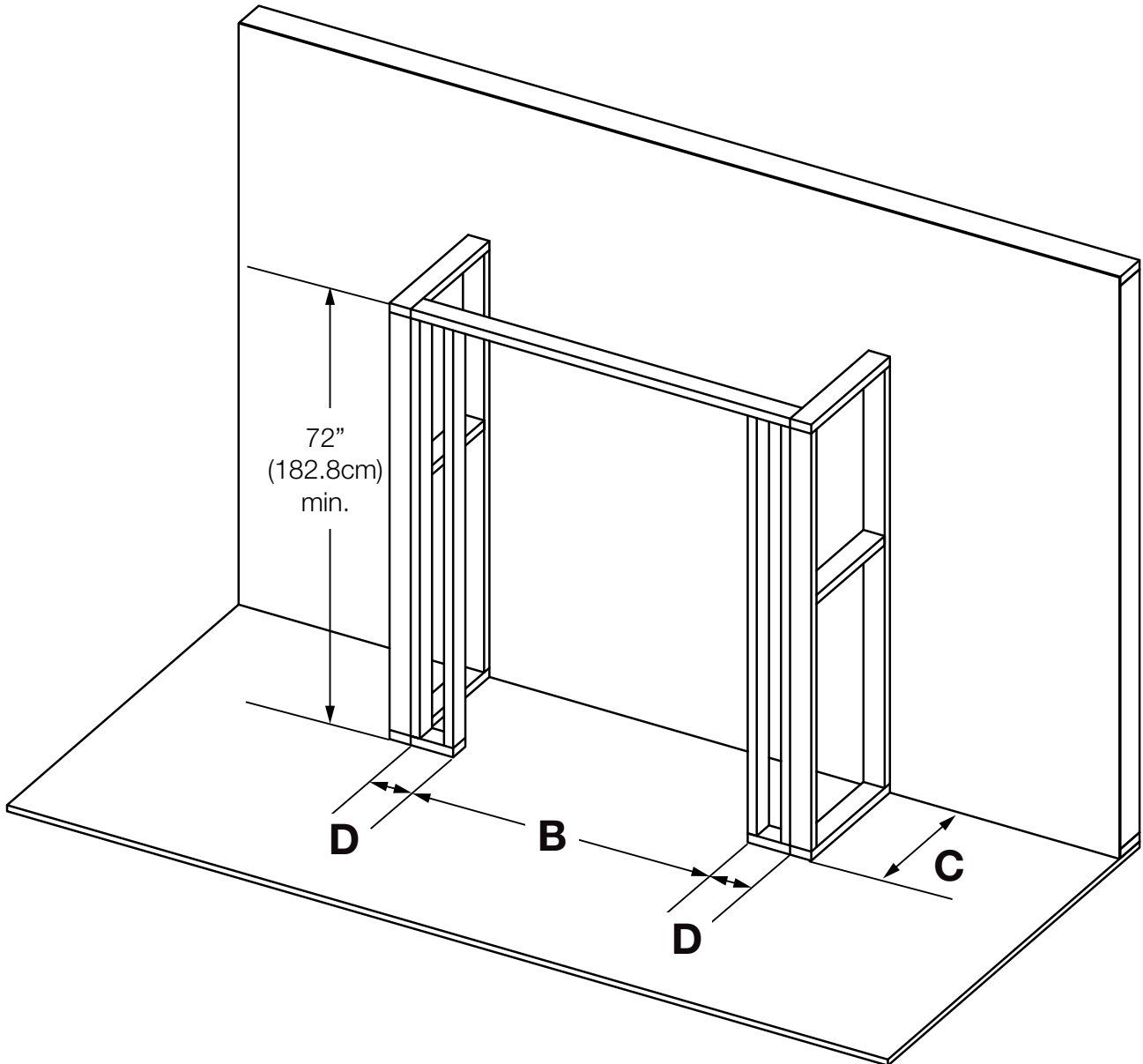

	EX36	EX42
B	42 3/4" (1086mm)	48 3/4" (1238mm)
C	22 1/4" (565mm)	
D	4 1/2" (114mm) min.	

3.2 minimum framing dimensions

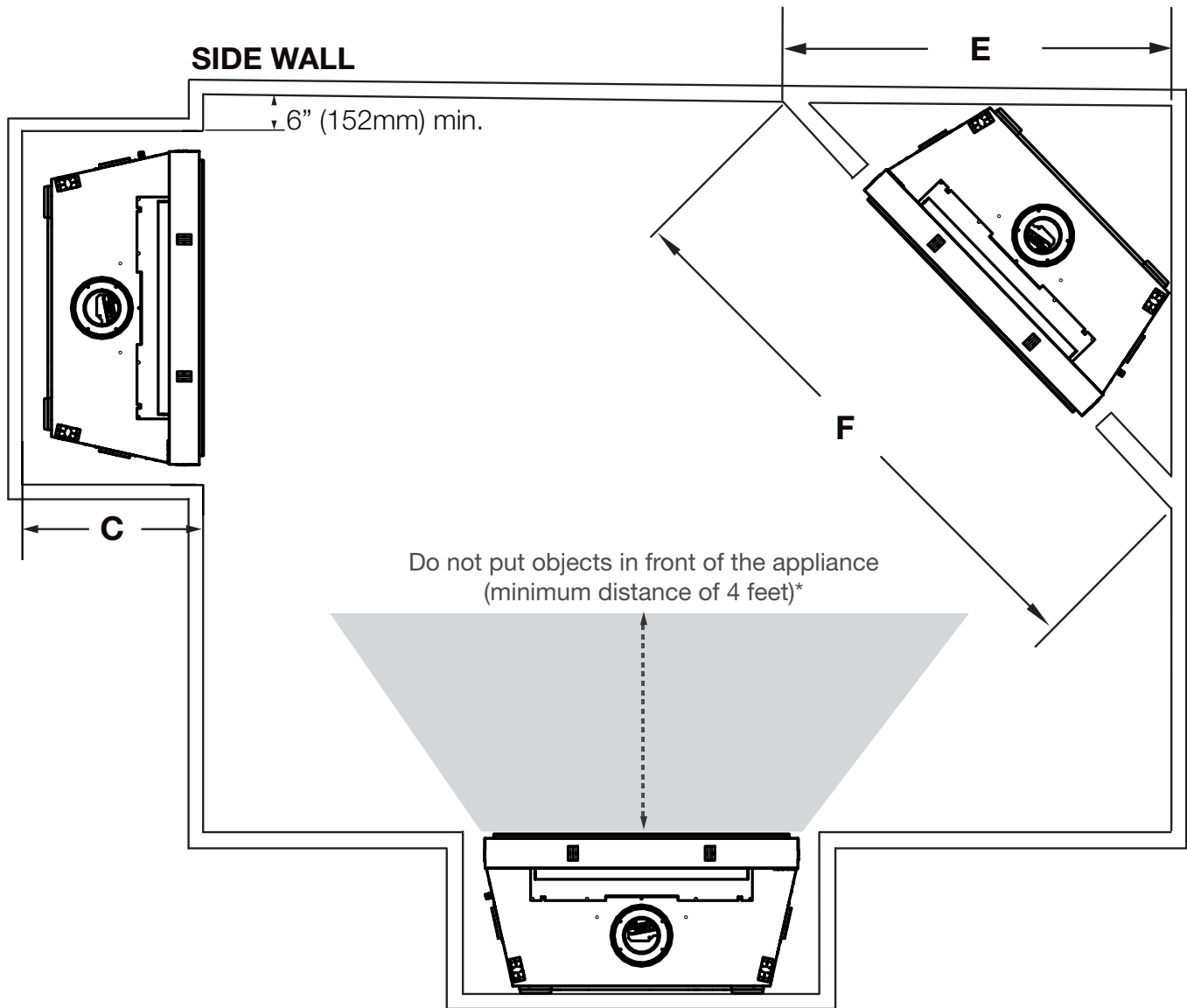

Horizontal vent sections: A minimum clearance of 3" (76mm) on the top of the vent to combustibles and 2" (51mm) on the sides and bottom of the vent to combustibles is required.

Vertical vent sections: A minimum clearance of 1" (25mm) all around the vent pipe on all vertical runs to combustibles is required.

	EX36	EX42
C	22 1/4" (565mm)	
E	55 3/8" (1407mm)	59 5/8" (1514mm)
F	78 5/16" (1989mm)	84 5/16" (2142mm)

rough framing

3.3 minimum clearance to combustible enclosures

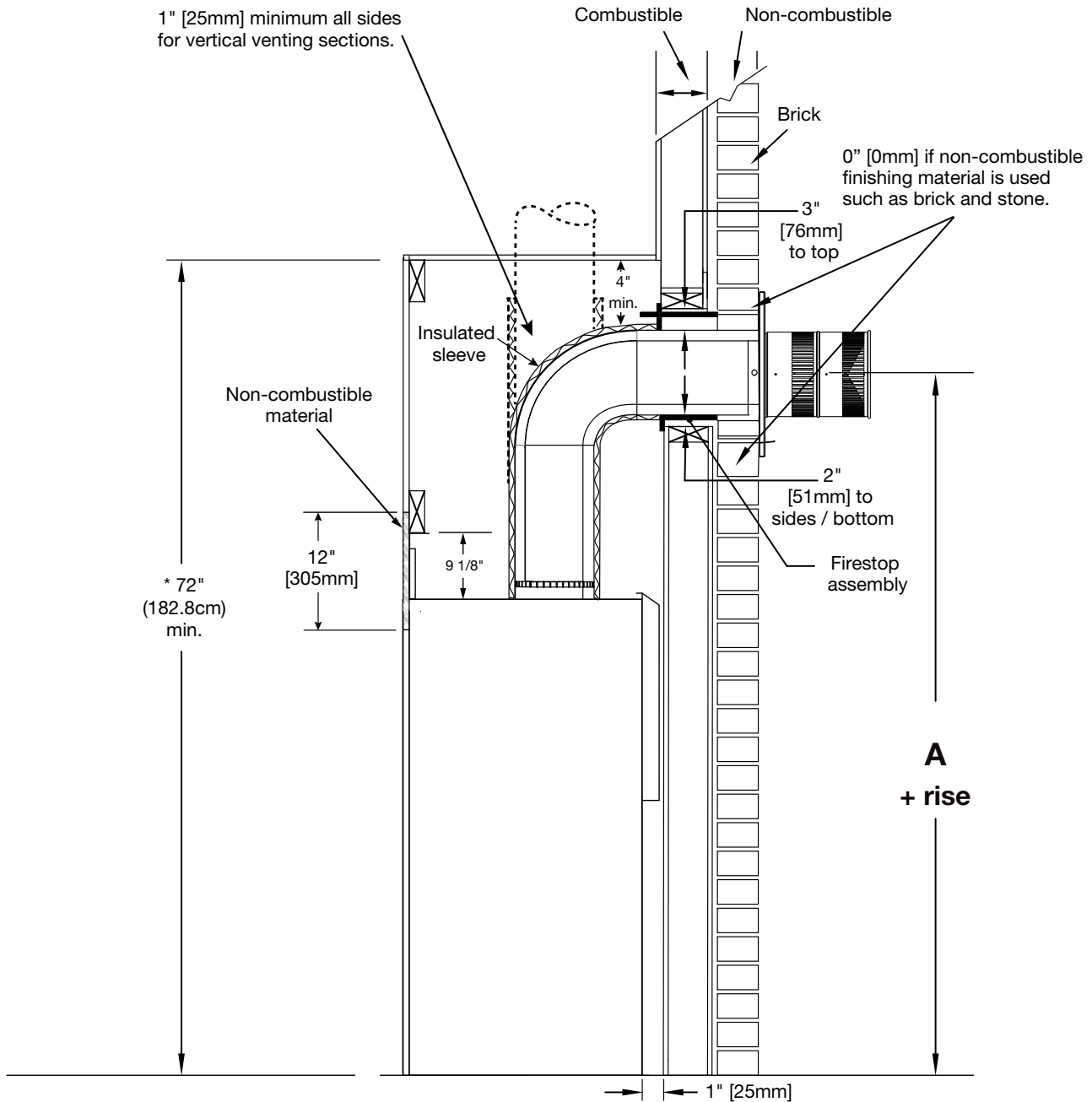

* Refer to "venting requirements" and "venting installation" sections.

** Clearances within the enclosure may be higher (refer to "minimum framing dimensions" section).

	EX36	EX42
A	59" (1499mm)	63" (1600mm)

⚠ WARNING

- Ensure to unpack all loose materials from inside the firebox prior to connecting the gas and electrical supply
- **If your appliance is supplied with a remote, ensure the remote receiver is in the “OFF” position prior to connecting the gas and electrical supply to the appliance.**
- For safe and proper operation of the appliance, follow the venting instructions exactly.
- **The appliance exhaust flue collar must be sealed using Mill Pac.** All exhaust and intake vent pipe joints must be sealed using red RTV high temp silicone sealant (W573-0002) (not supplied) or black high temp Mill Pac (W573-0007) (not supplied).
- If using pipe clamps to connect rigid vent components, a minimum of 3 screws must also be used to ensure the connection cannot slip off.
- Do not clamp the flexible vent pipe.
- Risk of fire, explosion, or asphyxiation. Improper support of the entire venting system may allow vent to sag and separate. Use vent run supports and connect vent sections per installation instructions.
- Risk of fire, do not allow loose materials or insulation to touch the vent pipe. Remove insulation to allow for the installation of the attic shield and to maintain clearances to combustibles.
- Do not fill the space between the vent pipe and enclosure with any type of material. Do not pack insulation or combustibles between ceiling firestops. Always maintain specified clearances around venting and firestop systems. Install wall shields and firestops as specified. Failure to keep insulation or other materials away from vent pipe may cause fire.
- **For gas stoves only:** If the appliance is installed directly on carpeting, vinyl tile, or other combustible material other than wood flooring, the appliance shall be installed on a metal or wood panel extending the full width and depth, unless otherwise tested.

For optimum performance, it is recommended that all horizontal runs have a minimum of 1/4" (6mm) rise per foot using flexible venting. For safe and proper operation of the appliance, follow the venting instructions exactly.

venting installation

4.1 horizontal installation

! WARNING

- The firestop assembly must be installed with the vent shield to the top.
- Terminals must not be recessed into a wall or siding more than the depth of the return flange of the mounting plate.
- The vent shield must be fixed in place by fastening the extended vent shield to the bend tabs using the supplied fasteners.

This application occurs when venting through an exterior wall. Having determined the correct height for the air terminal location, cut and frame a hole in the exterior wall, as illustrated, to accommodate the firestop assembly. Dry fit the firestop assembly before proceeding to ensure the brackets on the rear surface fit to the inside surface of the horizontal framing.

The vent shield must be installed to the full depth of the combustible wall. The length of the vent shield may cut shorter for combustible walls that less than 8 1/2" (216mm) thick.

note:

Bend the tabs for reduced side clearances or move the shield for reduced top clearances (dependent on specific appliance clearances). Do not fill the air space between the firestop spacer and the exterior wall with any type of insulating material (i.e. spray foam).

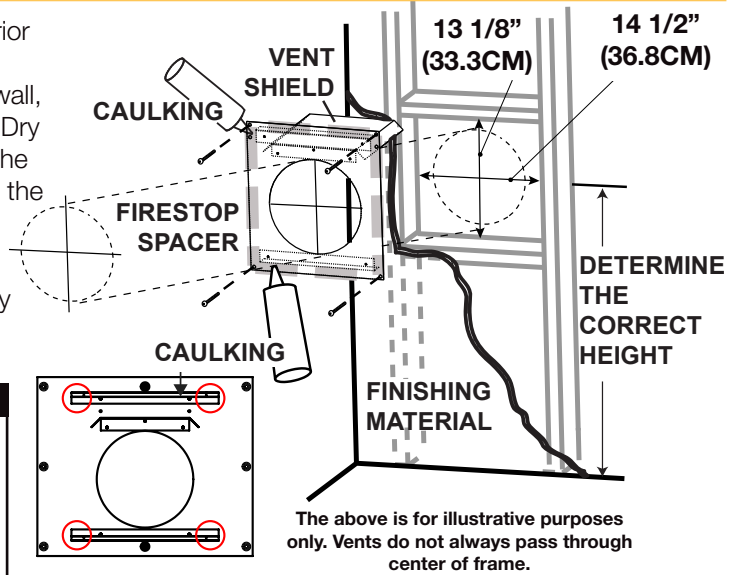

- Fold the vent shield up so that it is perpendicular to the spacer plate.
- Bend the tabs located on either side of the vent shield so that they are just shy of 90° to the spacer plate.
- On both sides of the firestop, fasten the (W570-0018) screws through the clearance holes in the bend tabs and threaded into the holes in the vent shield.
- Apply a bead of caulking around the outer edge of the firestop assembly.
- Screw the firestop onto the wall/framing, using 4 screws.
- Once the vent pipe is installed in its final position, apply red RTV silicone (W573-0002) (not supplied) between the pipe and the firestop.

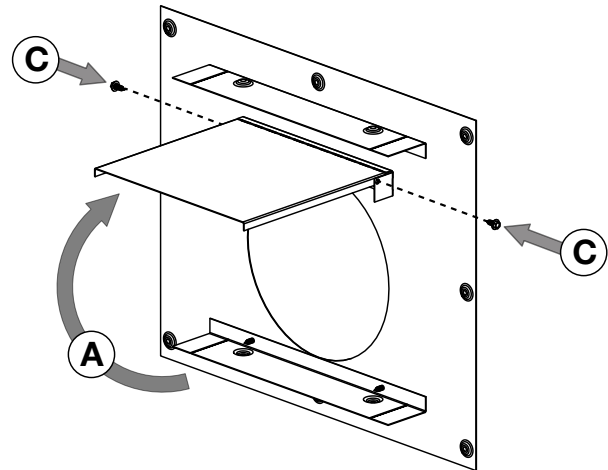

note:

Where the venting passes horizontally through a wall, you **MUST** use a Wolf Steel firestop for all rigid and flex vent systems. The gap between the outside diameter of the vent and the firestop **MUST** be completely sealed with high temperature RTV. When using flex venting, use firestop assembly W010-4479 (not supplied). When using rigid venting, use firestop assembly 5DFSH (not supplied).

4.2 vertical installation

This application occurs when venting through a roof. Installation kits for various roof pitches are available from your authorized dealer / distributor. See the “accessories” section to order specific kits required.

- A. Determine the air terminal location, cut and frame a square opening, as illustrated, in the ceiling and the roof to provide the minimum 1" (25mm) clearance between the vent pipe and any combustible material. Try to center the vent pipe location midway between two joists to prevent having to cut them. Use a plumb bob to line up the center of the openings. A vent pipe shield will prevent any materials such as insulation, from filling up the 1" (25mm) air space around the pipe. Nail headers between the joist for extra support.
- B. Apply a bead of caulking (not supplied) to the framework or to the Wolf Steel vent pipe shield plate or equivalent (in the case of a finished ceiling), and secure over the opening in the ceiling. A firestop must be placed on the bottom of each framed opening in a roof or ceiling that the venting system passes through. Apply a bead of caulking all around and place a firestop spacer over the vent shield to restrict cold air from being drawn into the room or around the fireplace. Ensure that both spacer and shield maintain the required clearance to combustibles. Once the vent pipe is installed in its final position, apply red RTV silicone (W573-0002) (not supplied) between the pipe and the firestop assembly.
- C. In the attic, slide the vent pipe collar down to cover up the open end of the shield and tighten. This will prevent any materials, such as insulation, from filling up the 1" (25mm) air space around the pipe.

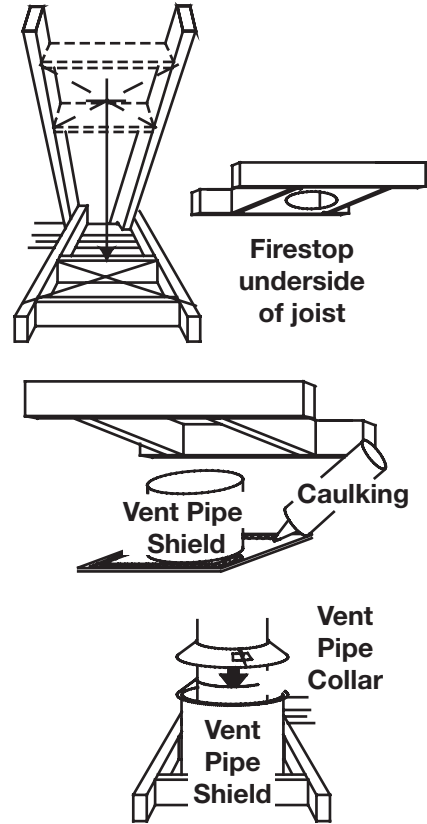

note:

When the venting passes vertically through a ceiling, you may use either Wolf Steel firestops or the venting manufacturer's firestops for rigid venting, provided they follow the required clearances listed in the appliance installation manual. For Wolf Steel flexible venting, you **MUST** use the Wolf Steel firestops listed below.

For 4"/7" appliances:

When using flex venting, use firestop assembly W500-0292 (not supplied).

When using rigid venting, use firestop assembly 4DFS (not supplied).

For 5"/8" appliances:

When using flex venting, use firestop assembly W500-0028 (not supplied).

When using rigid venting, use firestop assembly 5DFS (not supplied).

venting installation

4.3 using either flexible vent components

! WARNING

- Do not allow the inner flex pipe to bunch up on horizontal or vertical runs and elbows. Keep it pulled tight.
- Spacers are attached to the inner flex pipe at predetermined intervals to maintain an even air gap to the outer flex pipe. This gap is required for safe operation. A spacer is required at the start, middle, and end of each elbow to ensure this gap is maintained. These spacers must not be removed.

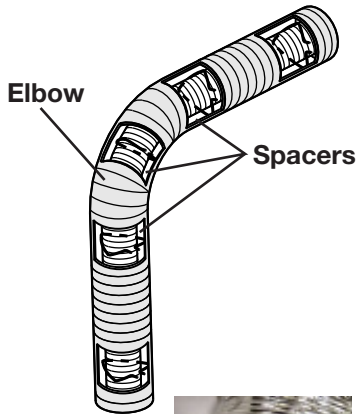

For safe and proper operation of the appliance, follow the venting instructions exactly.

The vent system must be supported approximately every 3 feet (0.9m) for both vertical and horizontal runs. Use Wolf Steel Ltd. support ring assembly or equivalent noncombustible strapping to maintain the minimum clearance to combustibles for both vertical and horizontal runs.

All inner flex pipe and outer flex pipe joints may be sealed using high temperature red RTV silicone W573-0002 (not supplied) or the high temperature sealant W573-0007 Mill Pac (not supplied). However, the high temperature sealant W573-0007 Mill Pac (not supplied) must be used on the joint connecting the inner flex pipe and the exhaust flue collar.

Use only approved flexible vent pipe kits marked:

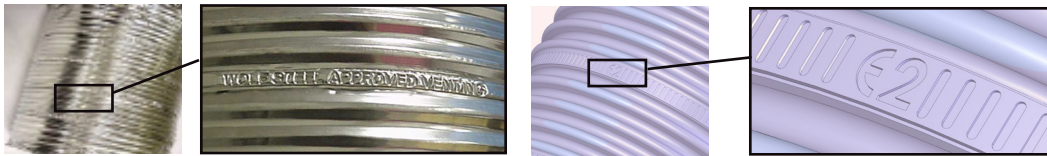

“Wolf Steel Approved Venting” or “E2” as identified by the stamp only on the flex pipes.

When installing using rigid vent components, follow the manufacturer’s installation and vent sealing requirements.

4.3.1 horizontal air terminal installation

- Stretch the inner flex pipe to the required length taking into account the additional length needed for the finished wall surface. Apply a heavy bead of the red RTV silicone (W573-0002) (not supplied) to the inner sleeve of the air terminal. Slip the vent pipe a minimum of 2" (50.8mm) over the inner sleeve of the air terminal and secure with a minimum of 3 screws.
- Using the outer flex pipe, slide over the outer combustion air sleeve of the air terminal and secure with a minimum of 3 screws. Seal using red RTV silicone (W573-0002) (not supplied).
- Insert the vent pipes through the firestop maintaining the required clearance to combustibles. Holding the air terminal (lettering in an upright, readable position), secure to the exterior wall and make weather tight by sealing with caulking (not supplied).
- If more vent pipe needs to be used to reach the fireplace, couple them together, as illustrated. The vent system must be supported approximately every 3 feet (0.9m) for both vertical and horizontal runs. Use non-combustible strapping to maintain the minimum clearance to combustibles.

#1 (x6)

#2 (x4)

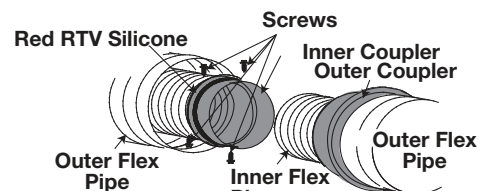
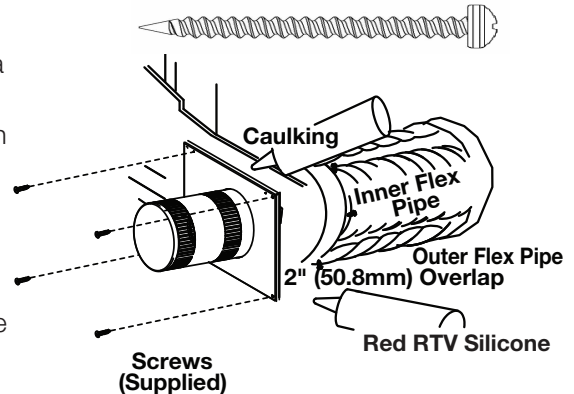

The air terminal mounting plate may be recessed into the exterior wall or siding no great than the depth of its return flange.

4.3.2 vertical air terminal installation

! WARNING

- Maintain a minimum 2" (51mm) space between the air inlet base and the storm collar.

note:

Fastening hardware provided with appropriate roof terminal and liner kits.

- A. Fasten the roof support to the roof using 6 screws. The roof support is optional. In this case, the venting is to be adequately supported using either an alternate method suitable to the authority having jurisdiction or the optional roof support.
- B. Stretch the inner flex pipe to the required length. Slip the inner flex pipe a minimum of 2" (51mm) over the inner pipe of the air terminal connector and secure with a minimum of three screws, when 4/7, 5/8 and 3/5 venting is used and a minimum of six screws when using 8/10 or 8/11 venting. Seal using a heavy bead of red RTV silicone sealant (W573-0002) (not supplied).
- C. Repeat using the outer flex pipe, using a heavy bead of red RTV silicone sealant (W573-0002) (not supplied) and a minimum of three screws, when 4/7, 5/8 and 3/5 venting is used and a minimum of six screws when using 8/10 or 8/11 venting.
- D. Thread the air terminal connector / vent pipe assembly down through the roof. The air terminal must be positioned vertically and plumb. Attach the air terminal connector to the roof support, ensuring that the top of the air terminal is 16" (40.6cm) above the highest point that it penetrates the roof.
- E. Remove nails from the shingles, above and to the sides of the air terminal connector. Place the flashing over the air terminal connector leaving a min. 3/4" (19mm) of the air terminal connector showing above the top of the flashing. Slide the flashing underneath the sides and upper edge of the shingles. Ensure that the air terminal connector is properly centered within the flashing, giving a 3/4" (19mm) margin all around. Fasten to the roof. Do not nail through the lower portion of the flashing. Make weather-tight by sealing with caulking. Where possible, cover the sides and top edges of the flashing with roofing material.
- F. Aligning the seams of the terminal and air terminal connector, place the terminal over the air terminal connector making sure the vent pipe goes into the hole in the terminal. Secure with a minimum of three screws, when 4/7, 5/8 and 3/5 venting is used and a minimum of six screws when using 8/10 or 8/11 venting.
- G. Apply a heavy bead of weatherproof caulking 2" (51mm) above the flashing. Install the storm collar around the air terminal and slide down to the caulking. Tighten to ensure that a weather-tight seal between the air terminal and the collar is achieved.
- H. If more vent pipe needs to be used to reach the appliance, see "**horizontal air terminal installation**" section.

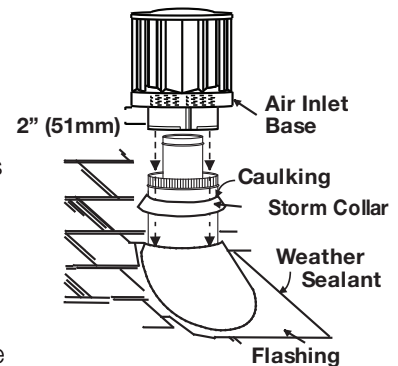
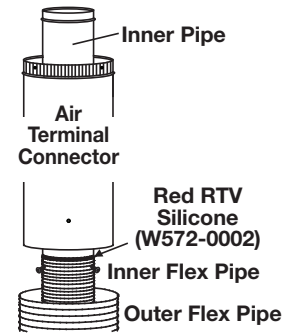
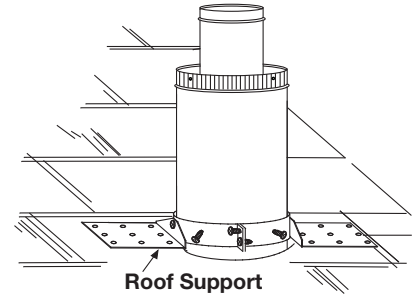

4.3.3 appliance vent connection

- A. Install the inner flex pipe to the appliance. Secure with a minimum of three screws when installing 3"/5", 4"/7" or 5"/8" venting, or six screws when installing 8"/10" or 8"/11" venting. Seal the joint and screw holes using Mill Pac sealant (W573-0007) (not supplied).
- B. Install the outer flex pipe to the appliance. Secure with a minimum of three screws when installing 3"/5", 4"/7" or 5"/8" venting, or six screws when installing 8"/10" or 8"/11" venting. Seal the joints using high temperature red RTV silicone (W573-0002) (not supplied).

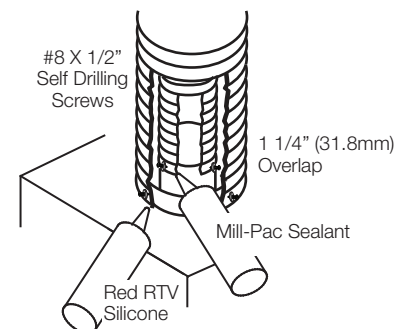

venting installation

4.3.4 restricting vents

! WARNING

- Turn off gas and electrical supply before servicing the appliance.
- Appliance may be hot, do not service until appliance is cool.
- For safe and proper operation of the appliance, follow the venting instruction exactly.
- To avoid danger of suffocation, keep the packaging bag away from babies and children. Do not use in cribs, beds, carriages or play pens. This bag is not a toy. Knot before throwing away.

Vertical installations may display a very active flame. If this appearance is not desirable, the exhaust outlet may be restricted with a Wolf Steel approved restrictor kit.

- The exhaust outlet reducer is factory installed for all vent configurations.
- Depending on the amount of restriction desired, the restrictor plate (supplied) can be installed flat for the most restriction or bent up for varying degrees of restriction.

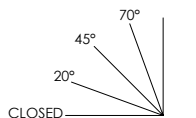
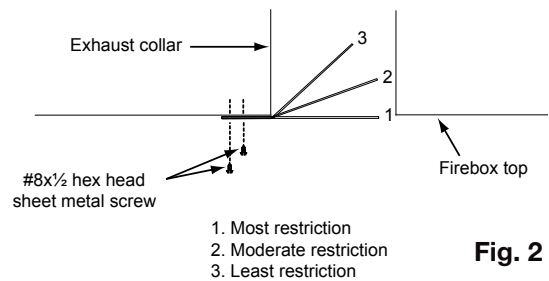
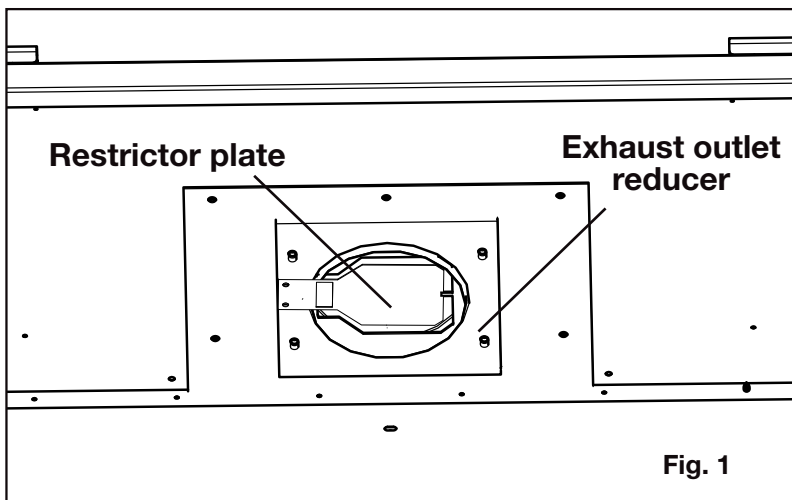

** FOR SEVERELY RESTRICTED VENT CONFIGURATIONS, THE PRE-INSTALLED REDUCER MAY BE REMOVED.

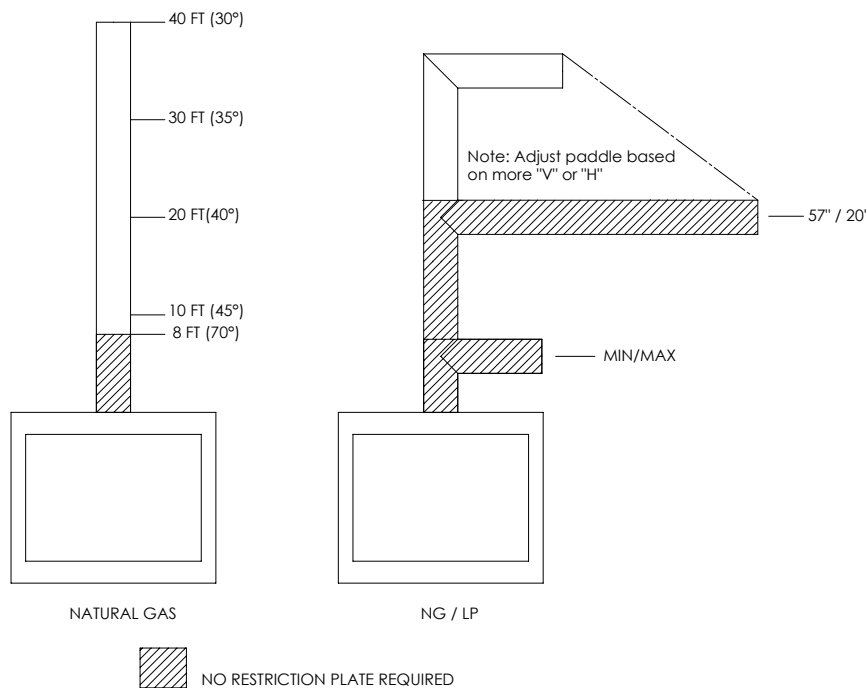

Fig. 3

5.1 hard wiring connection

It is necessary to hard wire this appliance.

This appliance must be electrically connected and grounded in accordance with local codes. In the absence of local codes, use the current CSA C22.1 Canadian Electrical Code in Canada or the ANSI/NFPA 70 National Electrical Code in the United States.

5.2 junction box installation

- A. Remove the two screws that secure the junction box assembly to the outer shell on the left side of the appliance and remove the junction box assembly.
- B. Remove the one screw that secures the junction box to the junction box plate and slide off the clip.
- C. Route the supply wire through the 7/8" (22.2mm) hole of the junction box plate with a box connector (not supplied).
- D. Connect the 120 volt supply wire to the receptacle as per the current CSA C22.1 Canadian Electrical Code in Canada or the current ANSI/NFPA 70 National Electrical Code in the United States.
- E. Once the wiring is complete, re-install the junction box to the junction box plate and re-secure the screw that was removed in step B.
- F. Re-install the junction box assembly by reversing step A making sure all plugs are secure in the junction box.

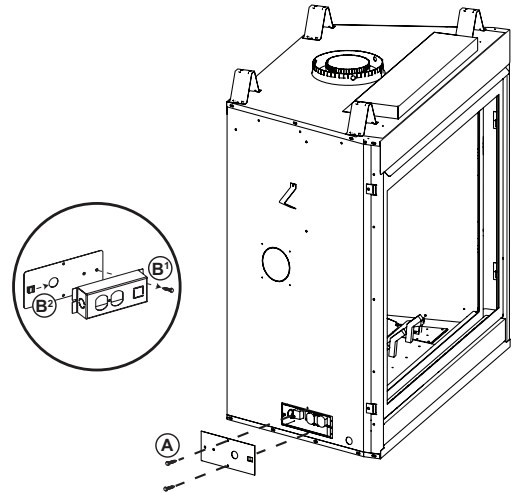

note:

If the appliance is already installed inside the enclosure, you can access the junction box from inside the appliance by removing the burner base assembly (see "accessing the blower" section).

5.3 electronic wiring diagram

⚠ WARNING

- Do not use this appliance if any part has been under water. Call a qualified service technician immediately to have the appliance inspected for damage to the electrical circuit.
- Risk of electrical shock or explosion. Do not wire 110V to the valve or to the appliance wall switch. Incorrect wiring will damage controls.
- All wiring should be done by a qualified electrician and shall be in compliance with local codes. In the absence of local codes, use the current CSA22.1 Canadian Electric Code in Canada or the current National Electric Code ANSI/NFPA NO. 70 in the United States.
- Always light the pilot whether for the first time or if the gas supply has run out, with the glass door opened or removed.

5.4 eFIRE Controller application

Napoleon's eFIRE application will revolutionize the way you use your fireplace! We have cracked the code and present to you the first fireplaces to be controlled by Bluetooth technology, using an intuitive app on your mobile device.

When fully equipped (if applicable), the eFIRE application allows you to select from a multitude of colours to suit your mood or décor simply by scrolling through the colour wheel. Additionally, Napoleon's eFIRE application allows you to control many other functions of your fireplace, including on/off, flame height, light feature, blower, and a timer to create a schedule for your fireplace that works for you.

Using the instructions on the eFIRE Controller application website <http://napoleon.com/efire>, install the application and enjoy the features the eFIRE Controller application has to offer. *

* Visit the website or contact your authorized dealer for appliance-specific information and/or frequently asked questions regarding features and products available with the eFIRE Controller application.

note:

The remote control is considered the master control for the appliance and can always be used to turn the appliance off (ex. the eFIRE Controller application user, in control of the appliance, leaves the home).

5.5 initializing the transmitter / battery holder for the first time

! WARNING

- Ensure the gas and electrical power to the appliance is turned off.
- Appliance may be hot, do not service until the appliance has cooled.

- Install the 4 AA batteries into the Proflame 2 battery holder, note the polarity of the batteries and insert as indicated on the cover (+/-).
- Ensure the 3 position slider switch is switched to the “REMOTE” position (middle position).
- Press the reset/programming button, use a small object such as a paper clip in order to reach the button marked PRG, as shown in the illustration below.
- The battery holder will beep 3 times to indicate that it’s ready to synchronize with the transmitter.
- Install the 3 AAA batteries into the transmitter, as shown in the photograph below, then press the ON button. The battery holder will beep 4 times to indicate that the transmitter’s command is accepted.

note:

The initializing process must be completed within 10 seconds of pressing the reset/programming button (PRG).

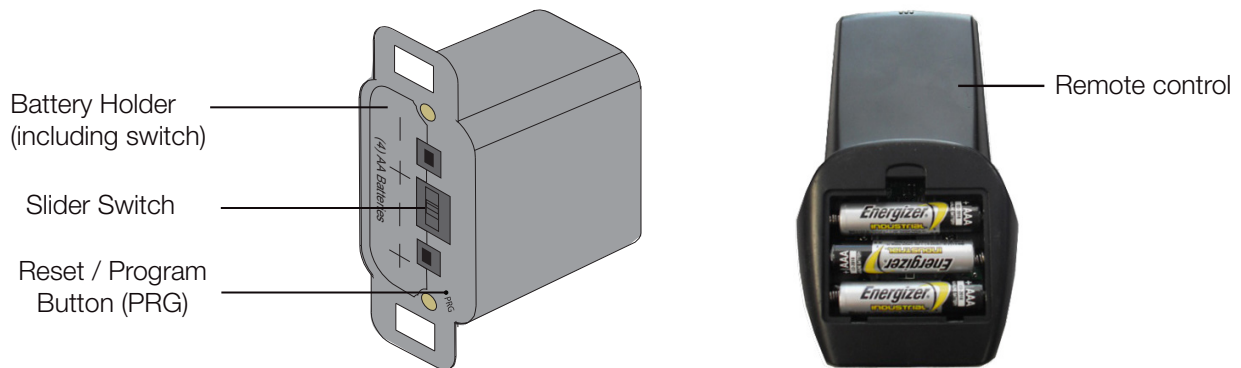

Receiver must be located within 8 feet (2.4m) of this side of the appliance and must be accessible for programming the remote.

Install the receiver into a standard electrical switch box. Determine an appropriate location and install the electrical box.

note:

Ensure the three position slider switch is in the “REMOTE” position (middle).

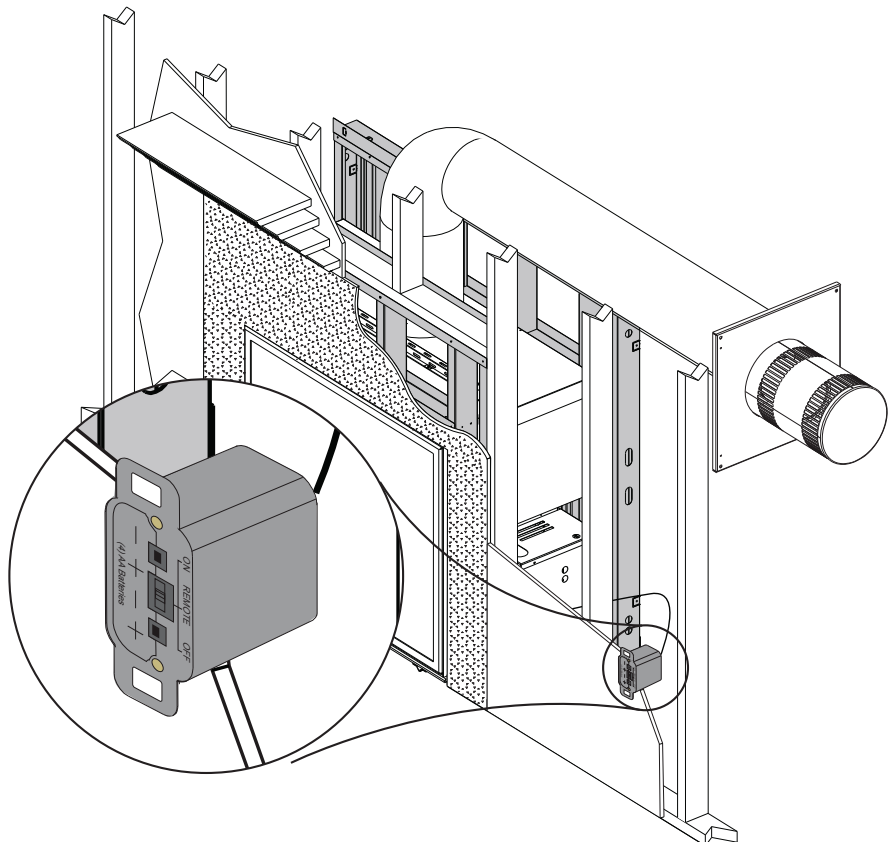

5.6 wiring diagram

! WARNING

- Do not wire 110 volts to the valve or wall switch.

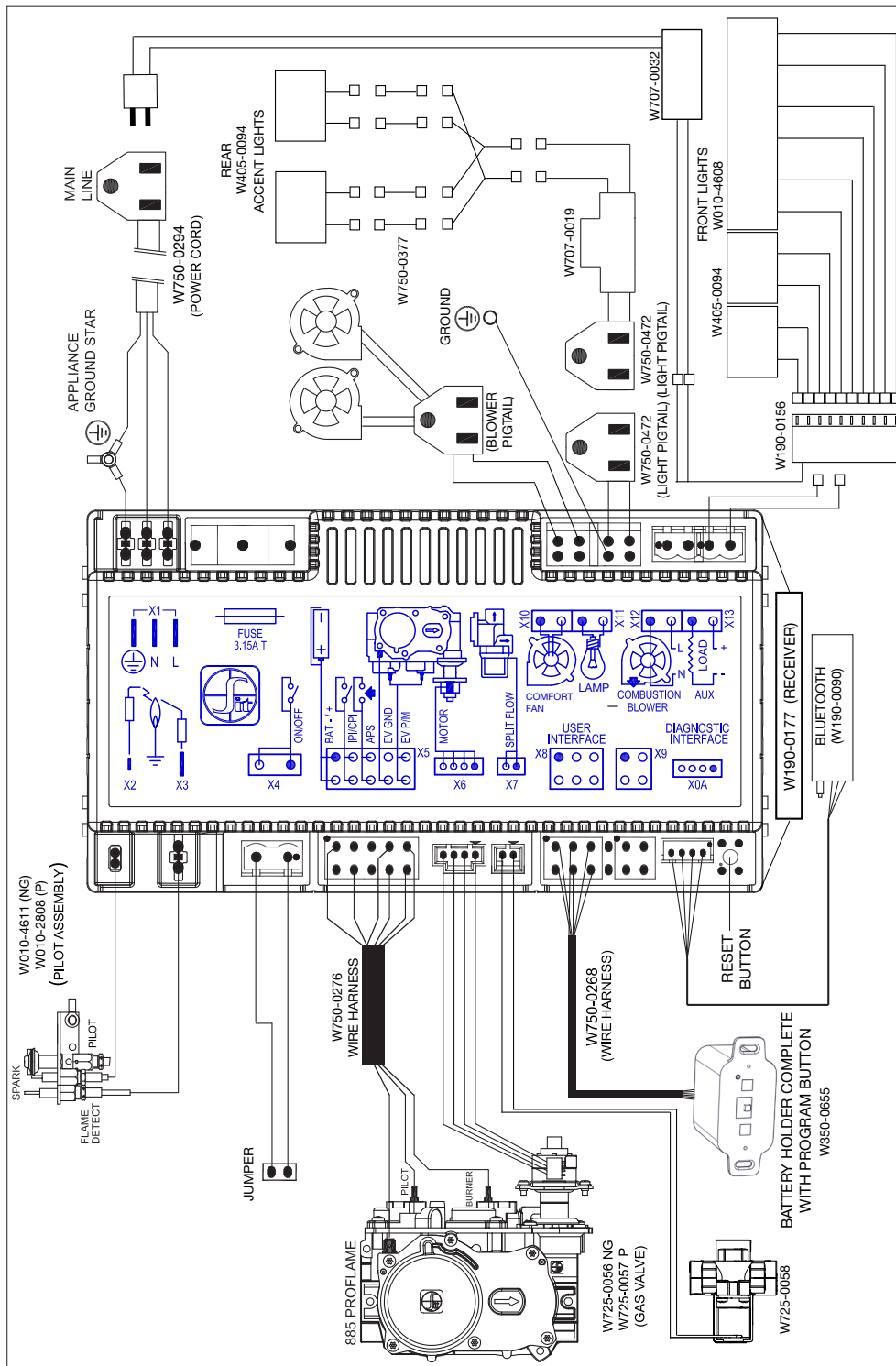

! WARNING

- Risk of fire, explosion, or asphyxiation. Ensure there are no ignition sources such as sparks or open flames.
- Support gas control when attaching gas supply pipe to prevent damaging gas line.
- Always light the pilot whether for the first time or if the gas supply has run out with the glass door opened or removed. Purging of the gas supply line should be performed by a qualified service technician. Ensure that a continuous gas flow is at the burner before closing the door. Ensure adequate ventilation. For gas and electrical locations, see “dimensions” section.
- All gas connections must be contained within the appliance when complete (**gas fireplaces only**).
- High pressure will damage valve. Disconnect gas supply piping before testing gas line at test pressures above 1/2 PSIG.
- Valve settings have been factory set, do not change.

Installation and servicing to be done by a qualified installer.

- Move the appliance into position and secure.
- If equipped with a flex connector, the appliance is designed to accept a 1/2” (13mm) gas supply. Without the connector, it is designed to accept a 3/8” (9.5mm) gas supply. The appliance is equipped with a manual shut off valve to turn off the gas supply to the appliance.
- Connect the gas supply in accordance to local codes. In the absence of local codes, install to the current CAN/CSA-B149.1 Installation Code in Canada or to the current National Fuel Gas Code, ANSI Z223.1 / NFPA 54 in the United States.
- When flexing any gas line, support the gas valve so that the lines are not bent or kinked.
- The gas line flex-connector should be installed to provide sufficient movement for shifting the burner assembly on its side to aid with servicing components.
- Check for gas leaks by brushing on a soap and water solution. **Do not use open flame.**

After installing the electrical wiring and gas lines, ensure to test the appliance before finishing the framing and finishing the appliance.

- Remove the 4 screws holding the grate into position.
- Remove the 6 screws securing the gas access panel.

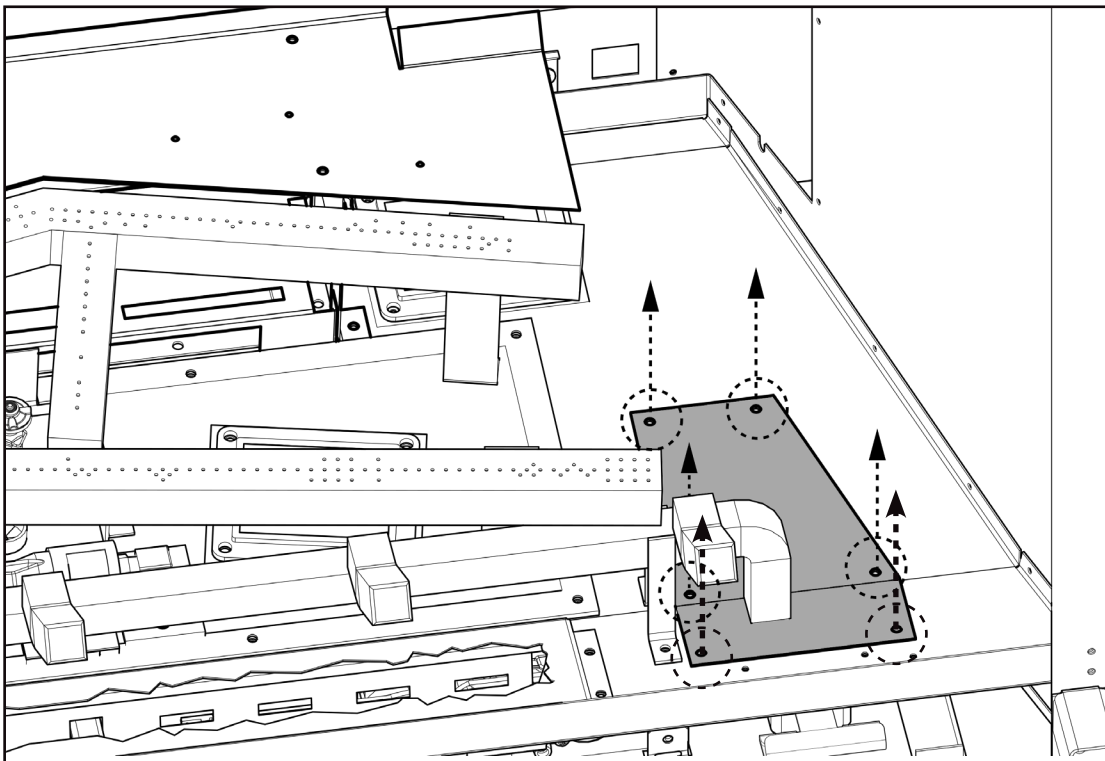

note:

A gas access hole has been provided to help with gas installation. Plate and gasket must be sealed before operation.

7.0 operation

⚠ WARNING

- If you do not follow these instructions exactly, a fire or explosion may result causing property damage, personal injury, or loss of life.
- If applicable, always light the pilot whether for the first time or if the gas supply has run out with the glass door opened or removed.

Ensure that a continuous gas flow is at the burner before installing the door. When lit for the first time, the appliance will emit an odor for a few hours. This is a normal temporary condition caused by the “burn-in” of paints and lubricants used in the manufacturing process and will not occur again. After extended periods of non-operation, such as, following a vacation or warm weather season, the appliance may emit a slight odor for a few hours. This is caused by dust particules in the heat exchanger burning off. In both cases, open a window to sufficiently ventilate the room.

FOR YOUR SAFETY READ BEFORE LIGHTING

- Do not turn on if children or other at risk individuals are near the appliance.
- This appliance is equipped with an ignition device which automatically lights the pilot. Do not try to light the pilot by hand.
- Before operating, smell all around the appliance area for gas and next to the floor because some gas is heavier than air and will settle on the floor.
- Do not use this appliance if any part has been under water. Immediately call a qualified service technician to inspect the appliance and replace any part of the control system and any gas control which has been underwater.

WHAT TO DO IF YOU SMELL GAS

- Turn off all gas to the appliance.
- Open windows.
- Do not try to light any appliance.
- Do not touch any electric switch; do not use any phone in your building
- Immediately call your gas supplier from a neighbour’s phone. Follow the gas supplier’s instructions.
- If you cannot reach your gas supplier, call the fire department.

LIGHTING INSTRUCTIONS

note:

This appliance is equipped with an ignition device which automatically lights the pilot. Do not try to light the pilot by hand.

- Stop! Read the above safety information on this label.
- Remove batteries from the transmitter and set thermostat to lowest setting, if equipped.
- Turn off all electrical power to the appliance.
- Open the glass door, if equipped.
- Turn the manual shut-off valve clockwise to the “OFF” position. (Shut-off valve is located on the flex connector).
- Wait five (5) minutes to clear out any gas. If you smell gas including near the floor, **STOP!** Follow the instructions above in the “WHAT TO DO IF YOU SMELL GAS” section. If you don’t smell gas; close the glass door and go to the next step.
- Turn the manual shut-off valve counter clockwise to the “ON” position.
- Turn on all electrical power to the appliance and re-install the batteries into the transmitter. Set thermostat to desired setting, if equipped.
- Turn on the remote wall switch to the appliance.
- If the appliance will not operate, follow instructions “TO TURN OFF GAS” and call your service technician or gas supplier.

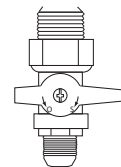

MANUAL SHUT-OFF
(SHOWN IN OFF POSITION)

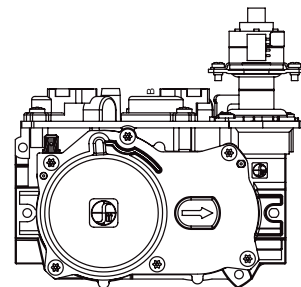

TO TURN OFF GAS

- Set thermostat to lowest setting, if equipped.
- Turn off the remote wall switch to the appliance.
- Turn off all electric power to the appliance if service is to be performed.
- Turn manual shutoff valve clockwise to the “OFF” positon. Do not force.

7.1 pilot-on-demand

This appliance is equipped with an “On Demand” intermittent pilot ignition system (IPI) which also includes a continuous pilot ignition (CPI) mode with an integrated seven day timer. This system minimizes your appliance’s carbon footprint as well as reducing its annual fuel consumption and operating costs.

In IPI mode, the pilot will ignite prior to the main burner, when the appliance is turned on using a switch, remote or from a call for heat with the thermostat (if equipped). Once the appliance is turned off (or the call for heat is satisfied), the main burner and pilot flame will shut down.

The continuous (CPI) mode is intended to enhance the performance of the appliance during the startup phase in colder climates and extreme weather by keeping the system warm when the main burner is not in use. However, the timer feature provides the convenience that the appliance automatically switches off the pilot when the appliance has not been used for seven days to save unnecessary fuel consumption.

When the CPI function is turned on, the pilot will remain on after the main burner is turned off. A timer will then begin the countdown for approximately seven days before shutting off the pilot if the appliance is not used. This countdown will reset anytime the appliance main burner is used. Therefore, if the appliance is regularly used day to day, the pilot will remain on. However, this system does not require the user to remember to turn the pilot off as summer approaches and avoids unnecessary fuel consumption while still readily turned back on when the cold weather returns.

Your appliance may be equipped with an ACS or remote control device (Fig. 1) which enables you to select IPI or CPI modes.

If your appliance is equipped with an ACS switch, it has the option to change modes:

Fig. 2: Flipping the switch ON turns on the continuous pilot with timer and flipping the switch OFF turns on the intermittent pilot ignition.

Fig. 3: If installed with the blue wire facing up, flipping the switch UP turns on the continuous pilot with timer and flipping the switch DOWN turns on the intermittent pilot ignition. If installed with the white wire facing up, the opposite is true.

If your appliance is equipped with a remote control device capable of selecting IPI / CPI modes, refer to remote operating instructions.

In order to start your pilot, turning the main burner on with the switch, remote or thermostat and then turning it off will reactivate the continuous pilot mode and reset the seven day timer.

For further information, refer to www.napoleon.com/pilotondemand



(Fig. 1)

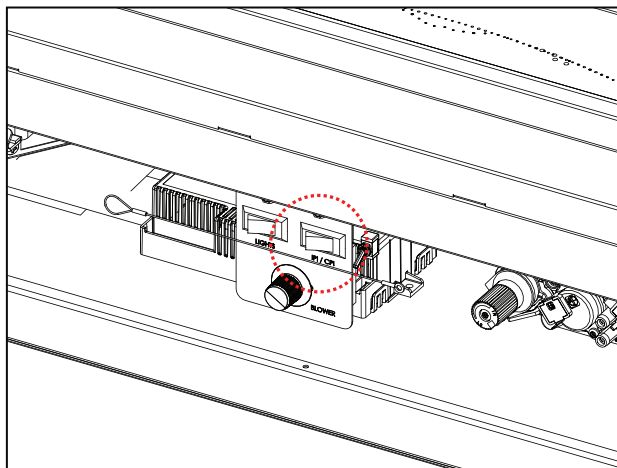

(Fig. 2)

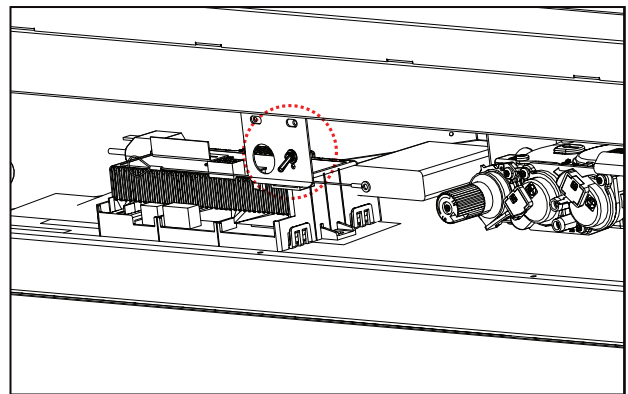

(Fig. 3)

8.0 finish framing

8.1 flush

! WARNING

- Risk of fire!
- Maintain all specified air space clearances to combustibles. Failure to comply with these instructions may cause a fire or cause the appliance to overheat.
- Ensure all clearances (i.e. back, side, top, vent, mantel, front, etc.) are clearly maintained.

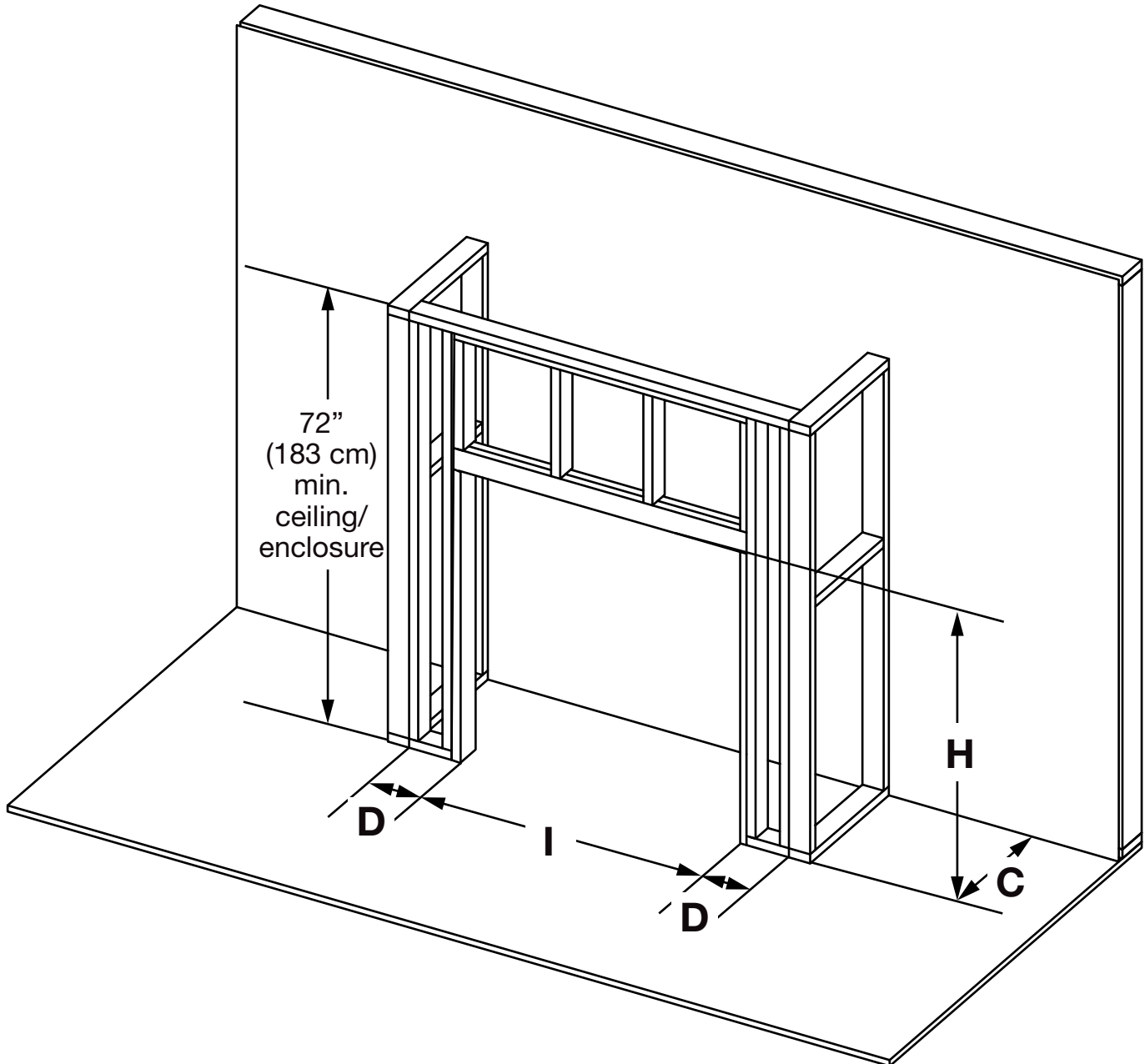

	EX36	EX42
H	44 1/4" (1124mm)	48 1/4" (1226mm)
I	39 3/4" (1010mm)	45 3/4" (1162mm)
D	6" (152mm) min.	
C	22 1/4" (565mm) min.	

8.2 recessed

! WARNING

- Risk of fire!
- Maintain all specified air space clearances to combustibles. Failure to comply with these instructions may cause a fire or cause the appliance to overheat.
- Ensure all clearances (i.e. back, side, top, vent, mantel, front, etc.) are clearly maintained.

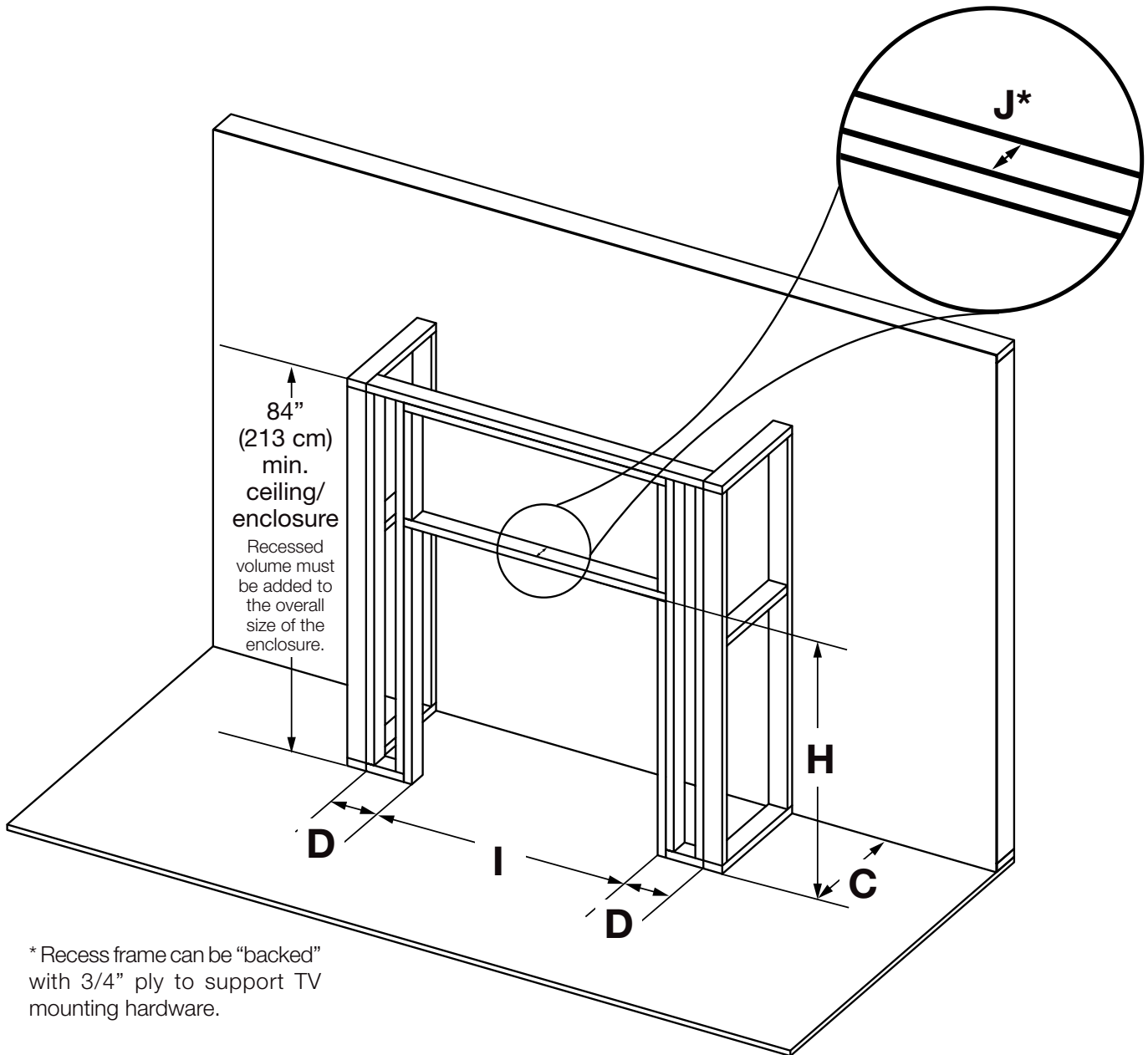

* Recess frame can be “backed” with 3/4” ply to support TV mounting hardware.

	EX36	EX42
H	44 1/4" (1124mm)	48 1/4" (1226mm)
I	39 3/4" (1010mm)	45 3/4" (1162mm)
D	6" (152mm) min.	
C	22 1/4" (565mm) min.	
J*	Max. 5 1/2" (140mm)	

9.0 finishing

⚠ WARNING

- Risk of fire!
- Never obstruct the front opening of the appliance.
- The front of the appliance must be finished with any non-combustible materials such as brick, marble, granite, etc., provided that these materials do not go below the specified dimension, as illustrated.
- Do not strike, slam, or scratch. Do not operate appliance with glass removed, cracked, or scratched.
- Facing and/or finishing material must never overhang into the appliance opening.
- The glass door assembly is designed to pivot forward when relieving excess pressure that might occur. Finishing or other materials must not be located in the opening surrounding the door as this will interfere with the doors ability to relieve pressure.

9.1 decorative panels

This appliance does not include decorative brick panels, however, panels are required. Panel kits are sold separately. Consult your local authorized dealer / distributor. Refer to the 'replacement parts' section.

9.2 log placement

⚠ WARNING

- Failure to position the logs in accordance with these diagrams or failure to use only logs specifically approved with this appliance may result in property damage or personal injury.
- Logs must be placed in their exact location in the appliance. Do not modify the proper log positions, since appliance may not function properly and delayed ignition may occur.
- The logs are fragile and should be handled with care.

Logs and glowing embers exclusive to Napoleon, provide a unique and realistic glowing effect that is different in every installation. Take the time to carefully position the glowing embers for a maximum glowing effect. Log colours may vary. During the initial use of the appliance, the colours will become more uniform as colour pigments burn in during the heat activated curing process. Blocked burner ports can cause an incorrect flame pattern.

OLKEX36

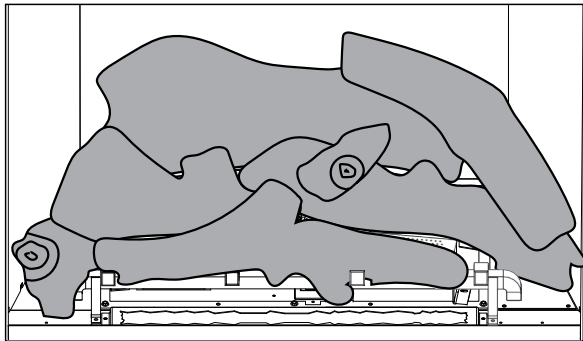

DLKEX42

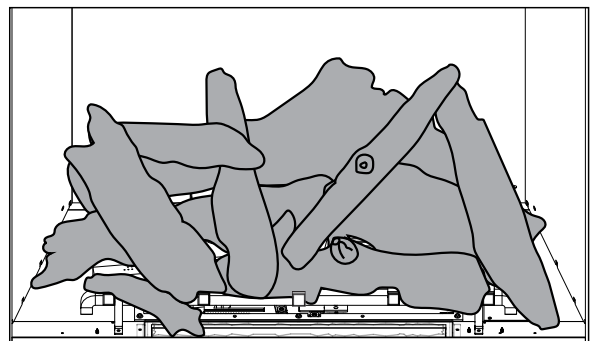

Refer to leaflet provided with kit for log placement instructions.

9.3 glowing embers

! WARNING

- Completely blocking the burner ports can cause an incorrect flame pattern, carbon deposits and delayed ignition.

Tear the embers into pieces and loosely layer above the burner ports covering the burner area. Care should be taken to shred the embers into thin, small irregular pieces as only the exposed edges of the fibre hairs will glow. *The ember material will only glow when exposed to direct flame; however, care should be taken to not block off the burner ports.*

Blocked burner ports can cause an incorrect flame pattern, carbon deposits and delayed ignition. Logs glow when exposed to direct flame. Use only certified glowing embers and logs available from your local authorized dealer / distributor. See log installation leaflets for details.

9.4 charcoal embers

! WARNING

- Do not block or close off the burner ports. Blocked ports can cause an incorrect flame pattern, carbon deposits and delayed ignition.
- When supplied, charcoal embers, charcoal lumps and vermiculite are not to be placed on the burner.

Blocked burner ports can cause an incorrect flame pattern, carbon deposits and delayed ignition. Logs glow when exposed to direct flame. Use only certified charcoal embers and logs available from your local authorized dealer / distributor. See log installation leaflets for details.

9.5 media placement

Some components have been hidden for clarity.

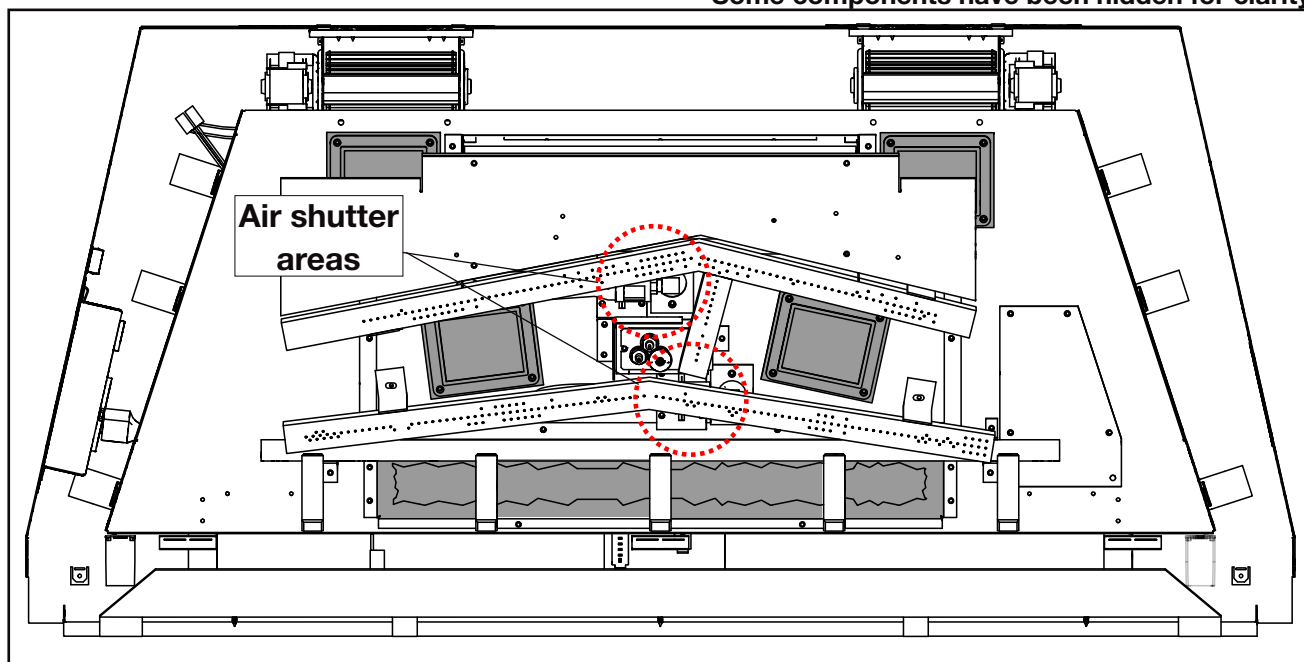

- Cover all lenses completely with clear glass (shaded area).
- Spread small amounts of amber glass over the clear glass to give the ember bed effect (shaded area).
- Place charcoal chips in the front corners and down the sides. Additionally, spread a small amount over the front light ember bed.
- Refer to log installation leaflet for further details.

note:

Ensure to keep air shutter areas free from media.

It is recommended that the rear 2 accent lights are covered when installing porcelain panels. It is optional with brick panels.

9.6 safety barrier & glass door installation / removal

! WARNING

- Glass may be hot. Do not touch glass until cooled.
- If equipped with door latches that are part of a safety system, they must be properly engaged. Do not operate the appliance with latches disengaged.
- Facing and/or finishing materials must not interfere with air flow through air openings, louvre openings, operation of louvres, or doors/access for service. Observe all clearances when applying combustible materials.
- Before door is removed, turn the appliance off and wait until appliance is cool to the touch. Doors are heavy and fragile so handle with care.

A barrier designed to reduce the risk of burns from the hot viewing glass is provided with the appliance and must be installed.

Before the glass door can be removed, the safety screen must be removed. Lift the safety screen up and away from the appliance.

Remove the bottom door trim. Leave a hand on the glass door during entire door removal. The glass door is secured to the firebox with 6 spring latches.

Pull the handles of the latches forward (door latch tool supplied in manual baggie), then lift the latches out from the door frame to release the door. Next, pivot the door forward until the top edge clears the front of the appliance. Carefully grip the sides of the door lifting it off the appliance.

Reverse these steps to re-install the safety screen and door. Ensure safety screen is installed correctly.

note:

These spring latches make up the spring relief system for the appliance. Ensure they open freely and close sealed.

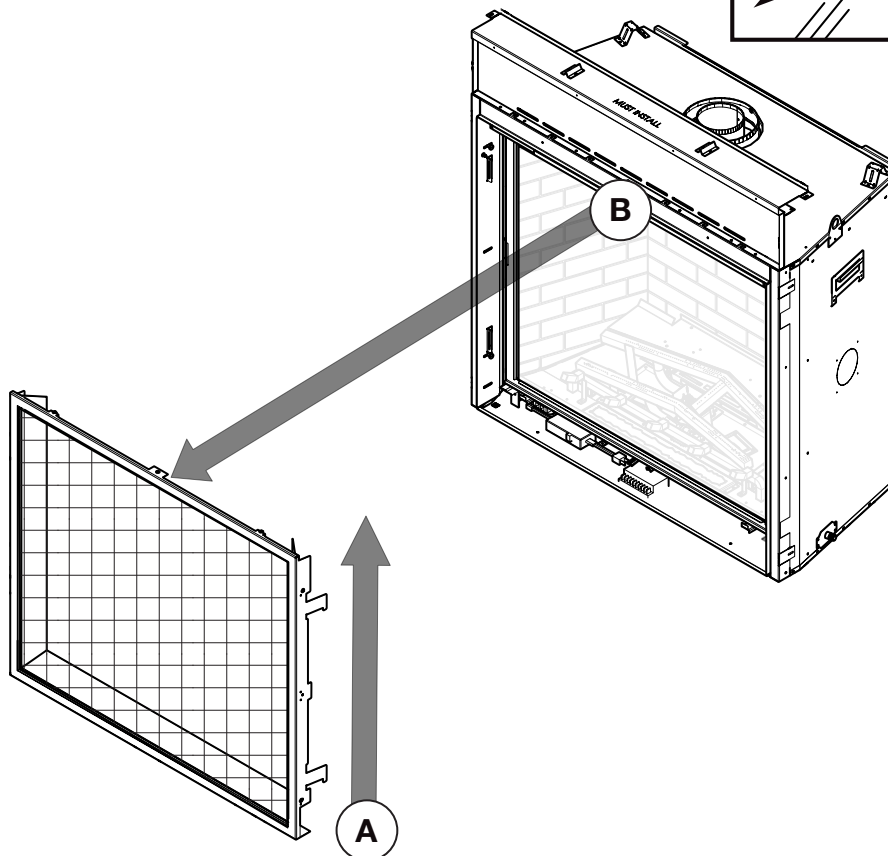
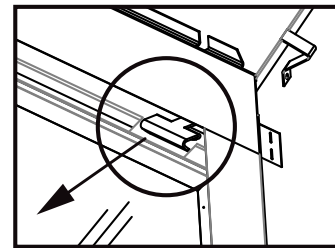

9.7 installing non-combustible board (non-DHM/DHC install)

! WARNING

Non-combustible facing material must not project more than 4" (101.6mm) from the face of the door (all four sides). If greater projections are desired, increase the clearance to the sides, bottom and top by 2" (50.8mm) for every additional 1" (25.4mm) of projection. If using an optional surround, the same rule applies, starting from the top of the surround. Ensure clearances are maintained for surround removal, as it must lift off the appliance for maintenance.

A non-combustibles kit is available for purchase. Consult your local authorized dealer / distributor.

Non-combustible top:

- Align pre-drilled holes in the non-combustible board with the pilot holes in the sheet metal.
- Secure the non-combustible panel to the appliance.

Non-combustible sides:

- Place the side non-combustible board against the appliance and tight to the top board.
- Mark the appliance to pre-drill holes.
- Secure the non-combustible panel to the appliance.

note:

Do not notch the framing around the appliance standoffs. Failure to maintain air clearance space could cause overheating and/or fire.

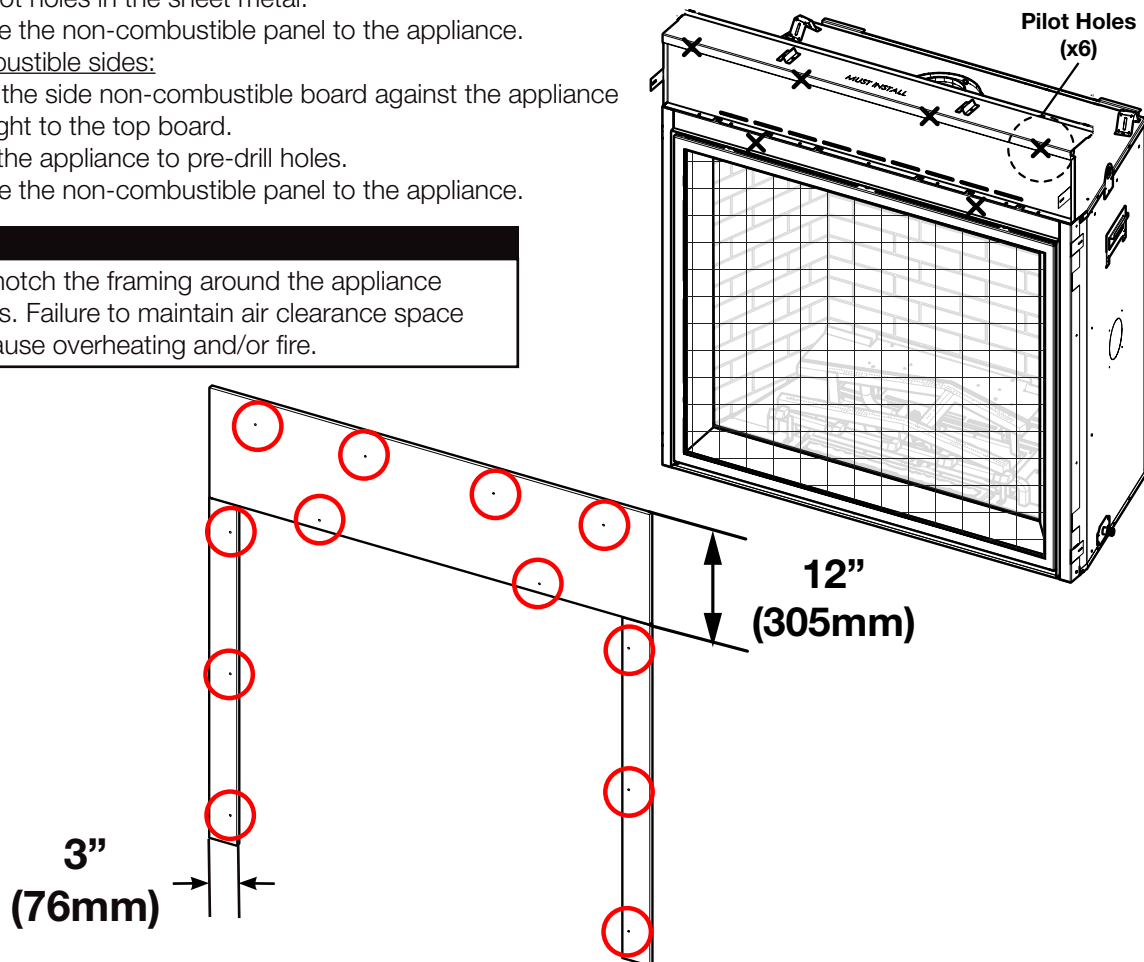

Joint Compound where required

Joint compounds such as Durabond 90 and tapes that are resilient to heat and cracking should be used when taping and mudding seams.

Setting tiles and grouting

We recommend you use tiles with a dry butt joint to be installed using a two-part mortar with an acrylic latex additive, such as Mapei Kerabond/Kerlastic, to allow for slight movement in the normal operation of the appliance. If grout is used between the tiles, a polymer-based grout, such as Mapei Ultracolor plus, is recommended.

Primer/Paint

For a painted surface, use a 100% acrylic latex primer and finish coat. Light coloured paints may discolour.

finishing

9.8 finishing flange adjustment

Depending on the thickness of finishing material we have allowed up to 1" (25mm) of adjustment after the 1/2" (13mm) non-combustible boards have been installed. Adjust the finishing flange to the desired position.

note:

Screw count varies by model.

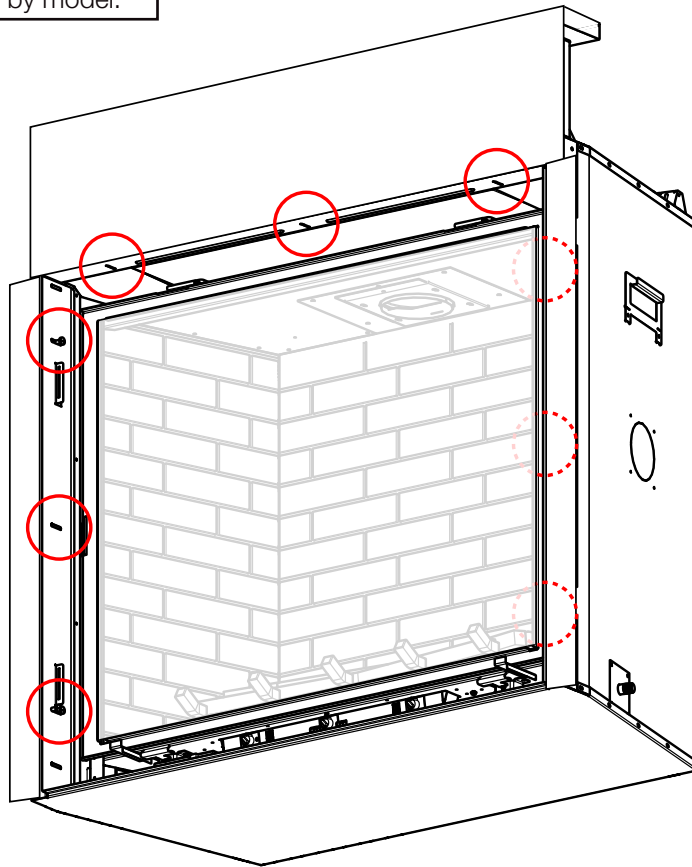

EX42
illustrated.

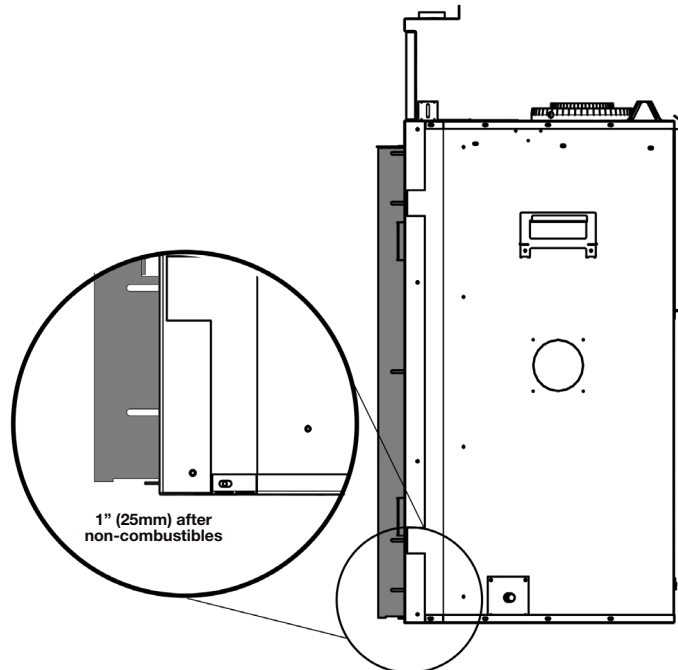

1" (25mm) after
non-combustibles

9.9 clearances around appliance

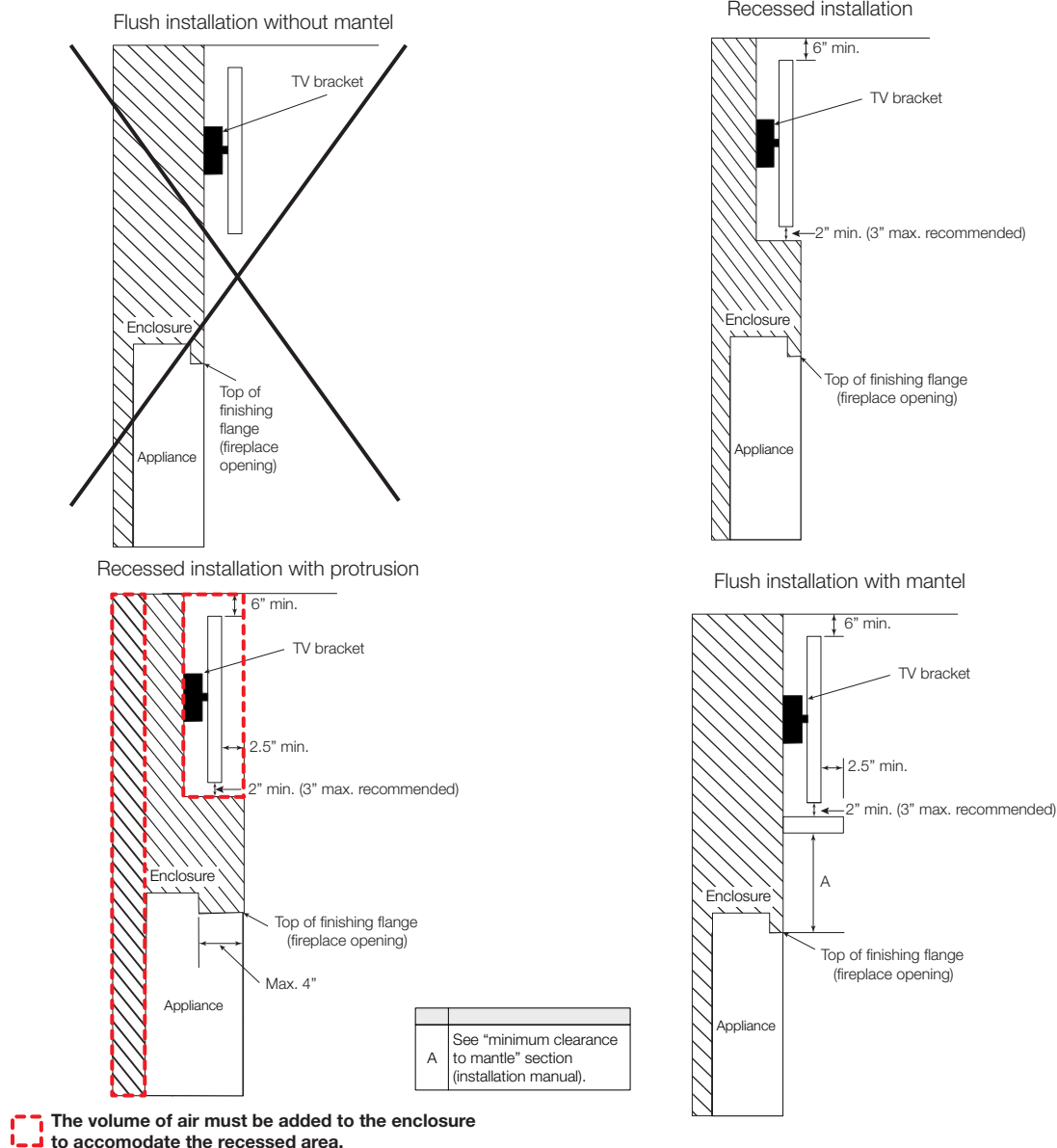

note:

- These are recommended minimum clearances only and are in supplied in good faith and not a guarantee of compliance with TV manufacturers' maximum allowable operating temperatures. Always comply to TV manufacturers' requirements.
- **TV temperatures must be validated at the time of installation** as air flow characteristics within the room can vary and maximum acceptable operating temperatures can vary from appliance to appliance. TVs cannot be used where the TV temperature exceeds the manufacturer's maximum allowable operating temperatures (see TV manufacturer's specifications).
- Mantel height and depth must conform to mantel clearance requirements specified in this manual, see "minimum clearance to combustible mantel" section in installation manual.
- Dimension "A" the gap between the top of the finishing flange and the bottom of the TV are taken from the top of the appliance opening.
- TV temperatures may be further reduced by increasing the horizontal distance between the front of the TV and the front edge of the mantel or by increasing dimension "A". However, increasing the gap between the top of the mantel and the bottom of the TV beyond the maximum recommended figure, typically results in higher temperatures. Minimum clearance between the mantel and bottom of the TV should be maintained to allow air circulation below and behind the TV.

9.10 minimum combustible mantel clearances

Combustible mantel clearance can vary according to the mantel depth. Use the graph to help evaluate the clearance needed.

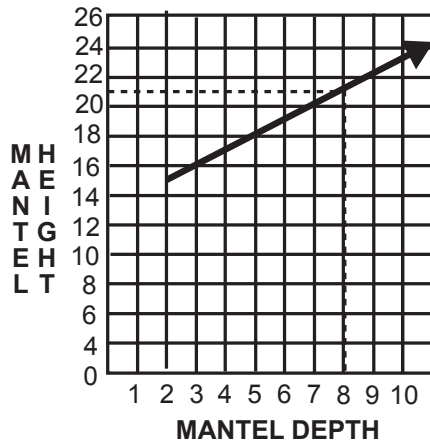

MANTEL DIMENSIONS		
Ref	Height	Depth
J	15" (381mm)	2" (51mm)
K	17" (432mm)	4" (102mm)
L	19" (483mm)	6" (152mm)
M	21" (533mm)	8" (203mm)

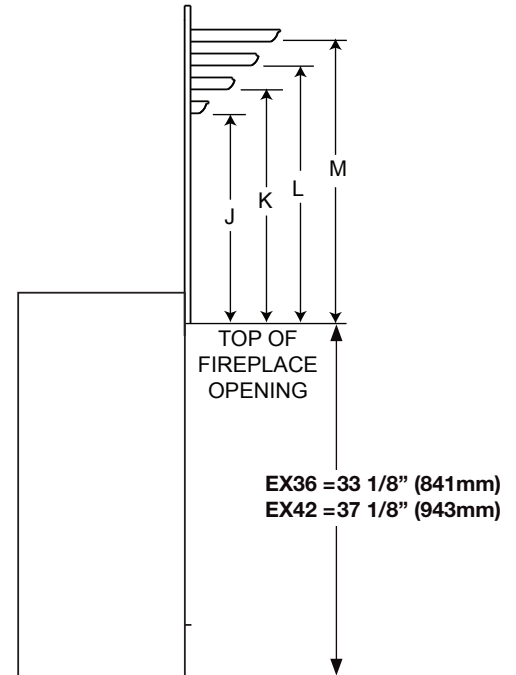

9.11 logo placement

Remove the backing of the logo supplied and place, as illustrated.

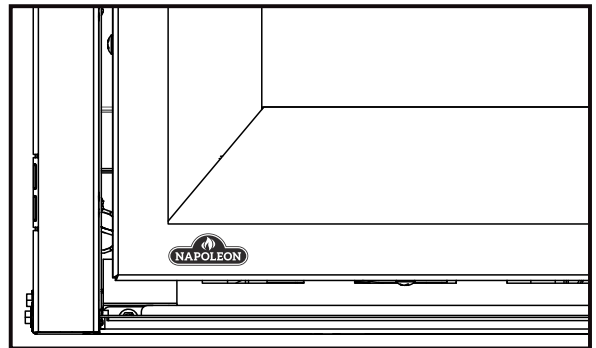

9.12 air shutter adjustment

note:

Adjustment may be required depending on fuel type, vent configuration and altitude.

This appliance has 2 primary air shutters that have been factory set to fully open.

Fine air adjustments should be made using the levers to achieve the desired flame (**FIG. 1**).

Regardless of venturi orientation, closing the air shutter will cause a more yellow flame, but can lead to carbonization. Opening the air shutter will cause a more blue flame, but can cause flame lifting from the burner ports. The flame may not appear yellow immediately; allow 15 to 30 minutes for the final flame colour to be established.

AIR SHUTTER ADJUSTMENT MUST ONLY BE DONE BY A QUALIFIED INSTALLER!

- A. Position the adjustment rod into the middle of the opening to disengage it from the securing notches (**Fig. 1**).
- B. Push in or pull out until desired flame is achieved.

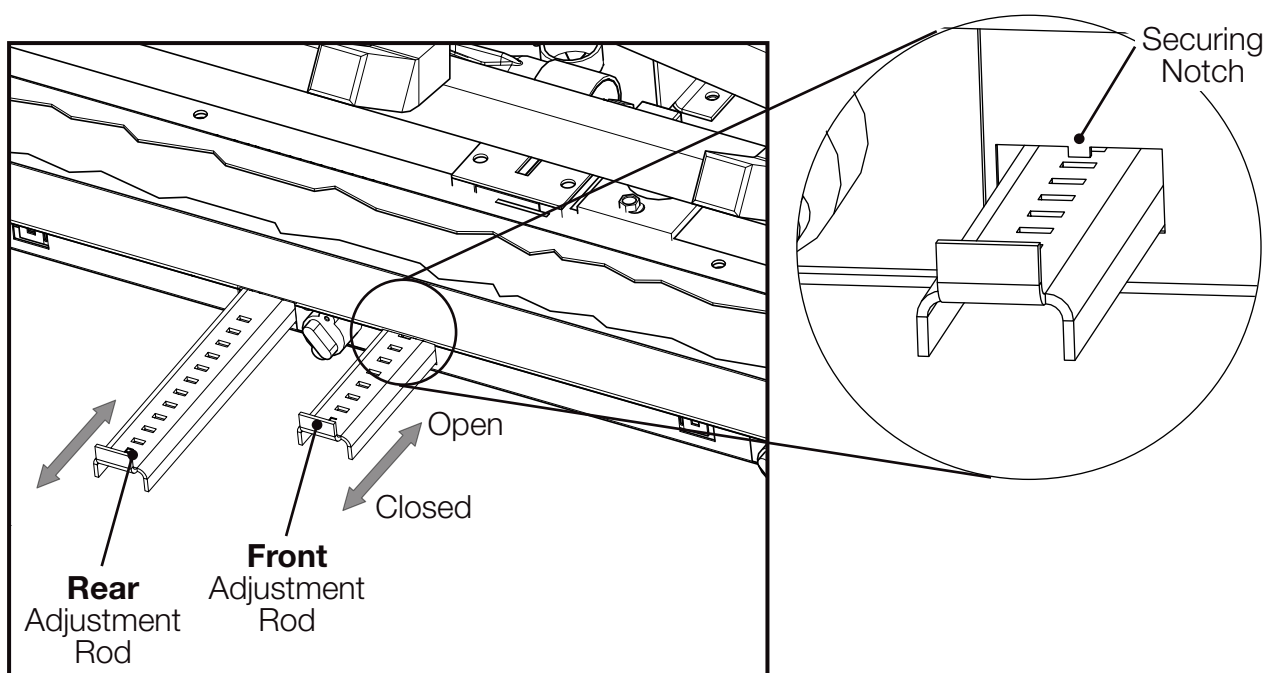

Fig. 1

9.13 pilot burner adjustment

Adjust the pilot screw to provide properly sized flame. Turn in a clockwise direction to reduce the gas flow.

Check Pressure Readings:

Inlet pressure can be checked by turning screw (A) counter-clockwise 2 or 3 turns and then placing pressure gauge tubing over the test point. Gauge should read as described on the chart below. Check pressure with main burner operating on "HI".

Outlet pressure can be checked the same as above using screw (B). Gauge should read as described on the chart below. Check pressure with main burner operating on "HI".

After taking pressure readings, be sure to turn screws clockwise firmly to reseal. Do not overtorque.

Leak test with a soap and water solution.

Prior to pilot adjustment, ensure that the pilot assembly has not been painted. If overspray or painting of the pilot assembly has occurred remove the paint from the pilot assembly, or replace. Fine emery cloth or a synthetic scrub pad (such as Scotch-Brite™) can be used to remove the paint from the pilot hood, electrode and flame sensor.

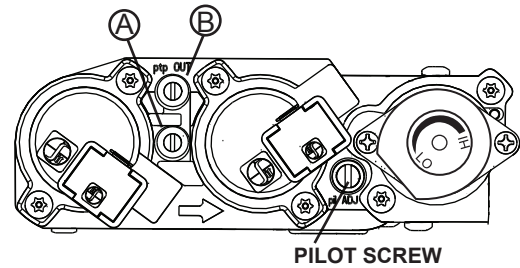

Pressure	Natural Gas (inches)	Natural Gas (millibars)	Propane (inches)	Propane (millibars)
Inlet	*7" (minimum 4.5")	17.4mb (minimum 11.2mb)	13" (minimum 11")	32.4mb (minimum 27.4mb)
Outlet	3.5"	8.7mb	10"	24.9mb

***Maximum inlet pressure not to exceed 13"**

9.14 flame characteristics

It's important to periodically perform a visual check of the pilot and burner flames. Compare them to the illustration provided. If any flames appear abnormal, call a service person.

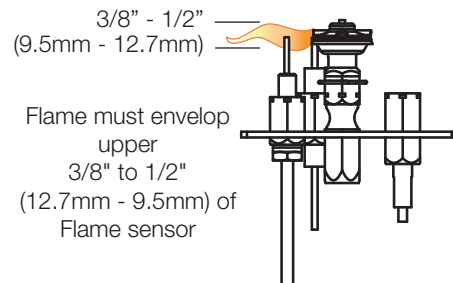

! WARNING

- Turn off the gas and electrical power before servicing the appliance.
- Appliance may be hot. Do not service until appliance has cooled.
- Do not use abrasive cleaners on glass.
- Do not paint the pilot assembly.

This appliance and its venting system (if equipped) should be inspected before use and at least annually by a qualified service person. The following suggested checks should be performed by a qualified technician. The appliance area must be kept clear and free of combustible materials, gasoline, or other flammable vapors and liquids. The flow of combustion and ventilation air must not be obstructed.

note:

Caution: Label all wires prior to disconnection when servicing controls. Wiring errors can cause improper and dangerous operation. Verify proper operation after servicing.

1. In order to properly clean the burner and pilot assembly, remove the logs, rocks and/or glass to expose both assemblies.
2. Keep the control compartment, media, burner, air shutter opening and the area surrounding the appliance clean by vacuuming or brushing, at least once a year.
3. Check to see that all burner ports are burning. Clean out any of the ports which may not be burning or are not burning properly.
4. Check to see that the pilot flame is large enough to engulf the flame sensor and/or thermocouple / thermopile as well as it reaches the burner.
5. If your appliance is equipped with a safety barrier, cleaning may be necessary due to excessive lint / dust from carpeting, pets, etc. simply vacuum using the brush attachment.
6. If your appliance is equipped with relief doors, ensure the system performs effectively. Check that the gasket is not worn or damaged. Replace if necessary.
7. Reinstall the cleaned logs, rocks or glass. Failure to properly position the media may cause carboning which can be distributed in the surrounding living area, inside the firebox and on exterior surfaces surrounding vent termination.
8. Check to see that the main burner ignites completely on all ports when turned on. A 5 to 10 second total light-up period is satisfactory. If ignition takes longer, consult your local authorized dealer / distributor.
9. Visually inspect the appliance for carbon build up. Using a small whisk or brush, brush off the carbon and vacuum up or sweep into garbage.
10. **This step is not applicable for Vent Free appliances:** Check to see that the appliance is venting correctly. Ensure chimney system is safe and unobstructed. (If for any reason the vent air intake system is disassembled, re-install and re-seal per the instructions provided for the initial installation).

10.1 care of glass**! WARNING**

- Do not clean glass when hot! Do not use abrasive cleaners to clean glass.

Buff lightly with a clean dry soft cloth to remove accumulated dust or fingerprints. Clean both sides of the glass after the first 4 hours of operation with an ammonia-free glass cleaner.

note:

Vinegar-based glass cleaners have demonstrated an ability to provide a clean, streak free glass surface.

Thereafter, clean as required. If the glass is not kept clean permanent discoloration and / or blemishes may result. Contact your local authorized dealer / distributor for complete cleaning instructions.

Razor blades, steel wool, or other metallic objects must not be used on both surfaces of the glass. Doing so can remove a thin layer of metal from the razor blades, steel wool, or other metallic objects that may then be deposited onto the coating. This can result in a discoloured stain or scratch-like mark. More importantly, this can scratch the glass surface, thereby reducing its strength.

Do not operate the appliance with broken glass, as leakage of flue gases may result.

Contact your local authorized dealer / distributor for complete cleaning instructions.

If the glass should ever crack or break while the fire is burning, do not open the door until the fire is out. Do not operate the appliance until the glass has been replaced. Contact you local authorized dealer / distributor for replacement parts. **DO NOT SUBSTITUTE MATERIALS.**

maintenance

This appliance is factory equipped with 5mm ceramic glass. Use only replacement parts as supplied by the appliance manufacturer. **DO NOT SUBSTITUTE MATERIALS.**

10.2 annual maintenance

WARNING

- Annual maintenance should be performed by a qualified service technician
- The firebox becomes very hot during operation. Let the appliance cool completely or wear heat resistant gloves before conducting service.
- Never vacuum hot embers.
- Do not paint the pilot assembly

- This appliance will require maintenance which should be planned on an annual basis.
- Service should include cleaning, battery replacement, venting inspection and inspection of the burner, media, and firebox. Refer to the door removal section and remove the door as instructed.
- Carefully remove media if necessary (logs, glass, brick panels, etc.).
- Using a vacuum with soft brush attachment, gently remove any dirt, debris, or carbon build up from the logs, firebox, and burner. For glass media, follow the installation instructions for pre-cleaning.
- Gently remove any build-up on the pilot assembly including thermopile, thermocouple, flame sensor, and igniter (if equipped).

note:

Clean flame sensor using a fine emery cloth or a synthetic scrub pad (such as Scotch-Brite™) to remove any oxides. Clean the pilot assembly using a vacuum with a soft brush attachment. It is important that the pilot assembly is not painted.

- Inspect all accessible gaskets and replace as required.
- If equipped with a blower, access the blower and clean using a soft brush and vacuum.
- Re-assemble the various components in reverse order.
- Inspect the relief system. The appliance relieves through the main glass door or through the flaps on the firebox top. Ensure they open freely, and close sealed.
- Check the gas control valve pilot and Hi / Lo knobs move freely, if equipped. Replace if any stiffness in movement is experienced.
- Check for gas leaks on all gas connections up and downstream from the gas valve including pilot tube connections.

10.3 glass / door replacement

WARNING

- Do not use substitute materials.
- Glass may be hot. Do not touch glass until cooled.
- Care must be taken when removing and disposing of any broken door glass or damaged components. Be sure to vacuum up any broken glass from inside appliance before operation.
- Do not strike, slam, or scratch. Do not operate appliance with glass removed, cracked, broken, or scratched.

Replacement glass/frame assembly shall be replaced as a complete unit as supplied by the appliance manufacturer.

10.4 ember bed light replacement

Your appliance comes equipped with our Night Light™ and ember bed lights. The lights have been pre-wired and can be controlled from your transmitter (see Owner's Manual for instructions).

In the event the lamp or lens needs to be replaced:

note:

Night lights are the back 2 lights. All others are considered ember bed lights.

The 3 front ember bed lights can be replaced from below the appliance along the front. The 2 night lights and 2 middle ember bed lights must be replaced from inside the firebox.

- Turn off power to the appliance.
- Remove the 4 screws securing the log support assembly. Remove and set aside **(Fig. 1)**.
- Remove the screws that secure lamp holder or the lens frame. This frame retains the glass lens **(Fig. 2)**.
- The lamp can now be accessed. Wiggle gently to pull straight out of the socket.

note:

Do not handle the lamp (bulb) with bare fingers at anytime. Oils from your fingers may damage the lamps. Use dry cloth or gloves during installation.

- Replace the lamp with Wolf Steel parts only, as lamp and lens are special "high temperature" products.
- When re-installing, ensure integrity of gasket seal.

note:

Do not over-tighten the screws, as this could break the lens.

THE FIREBOX MUST BE SEALED.

"Light leakage" from the lower area may be noticed. The holes in the lamp housing are necessary for ventilation and must not be covered.

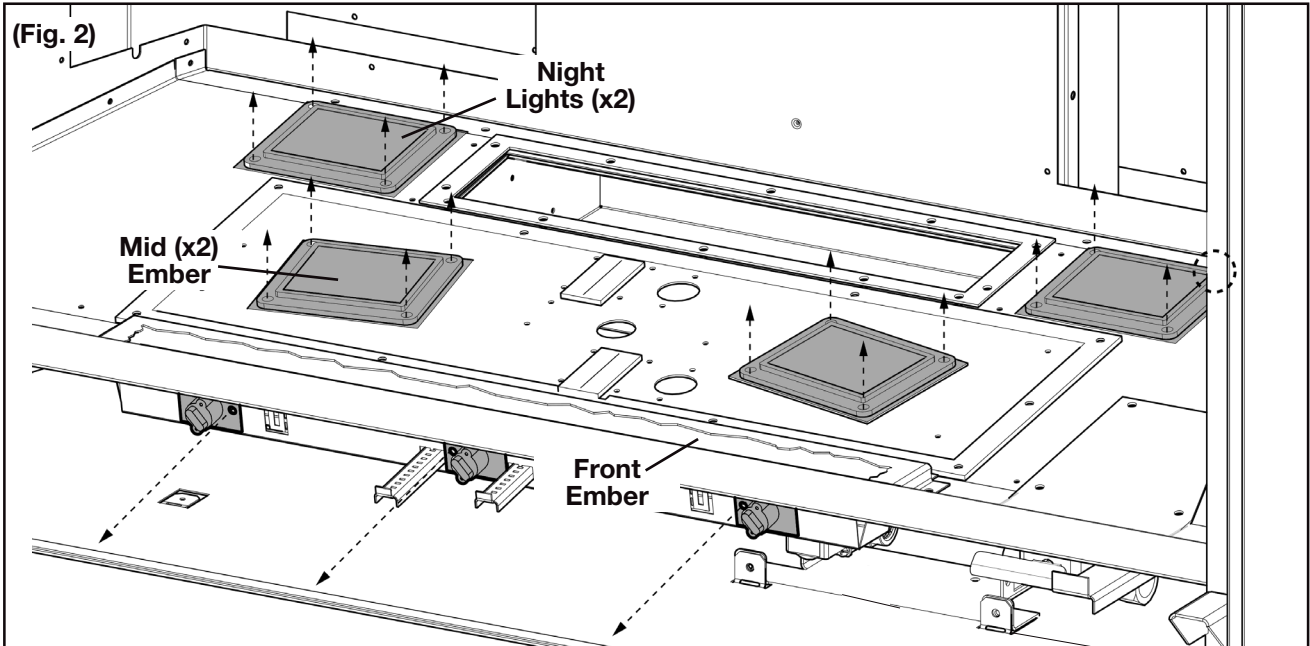
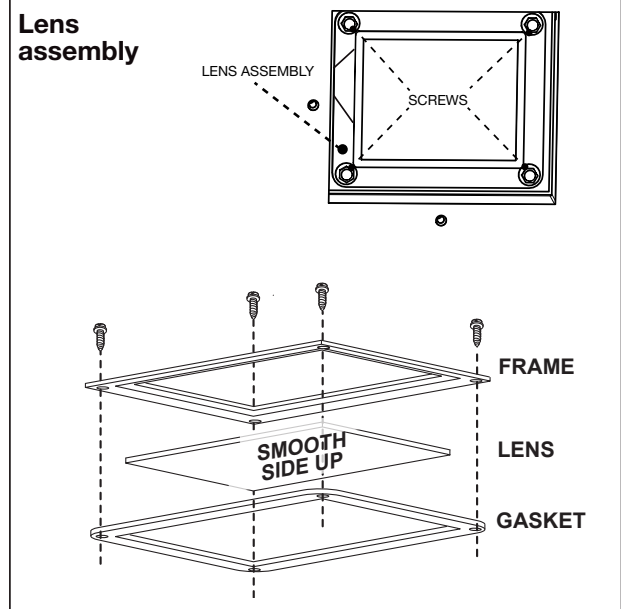
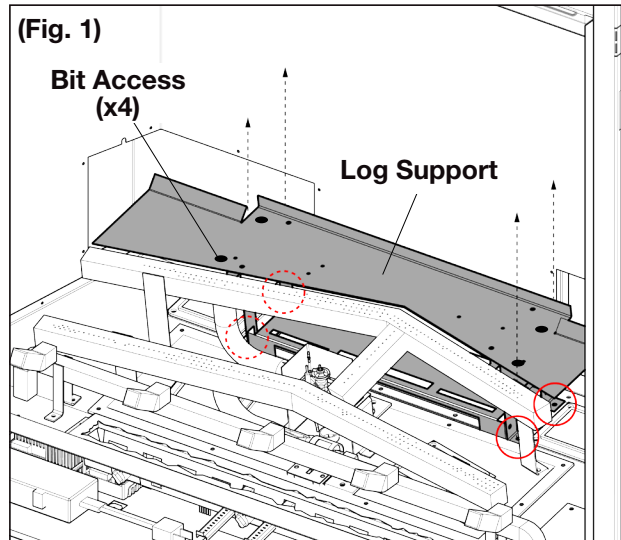

Some components have been hidden for clarity.

10.5 blower replacement

! WARNING

- Risk of fire and electrical shock!
- Turn off the gas and electrical power before servicing this appliance.
- Use only Wolf Steel approved optional accessories and replacement parts with this appliance. Using non-listed accessories (blowers, doors, louvres, trims, gas components, venting components, etc.) could result in a safety hazard and will void the warranty and certification.
- Ensure that the fan's power cord is not in contact with any surface of the appliance to prevent electrical shock or fire damage. Do not run the power cord beneath the appliance.
- The wire harness provided in the blower kit is a universal harness. When installed, ensure that any excess wire is contained, prevent it from making contact with moving or hot objects.

- Turn off the power to the appliance.
- Remove the safety barrier.
- Remove the main door assembly.
- Remove media and logs.
- Remove the 4 screws securing the log support assembly. Remove and set aside **(Fig. 1)**.
- This appliance is equipped with a left and right blower. Remove the access plate from the side being replaced **(Fig. 2)**.

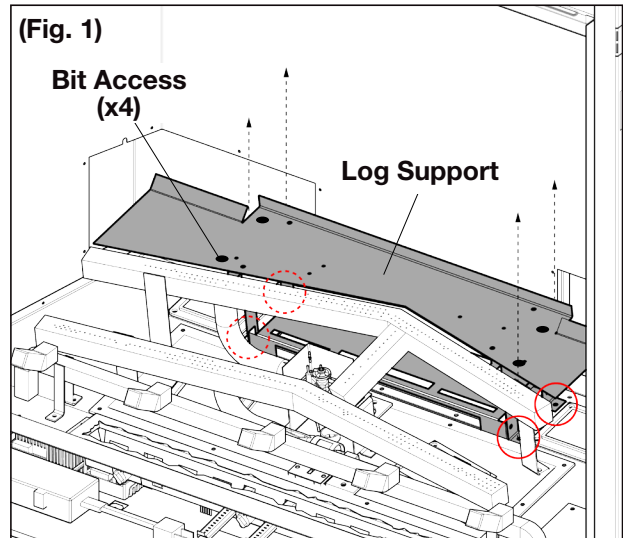
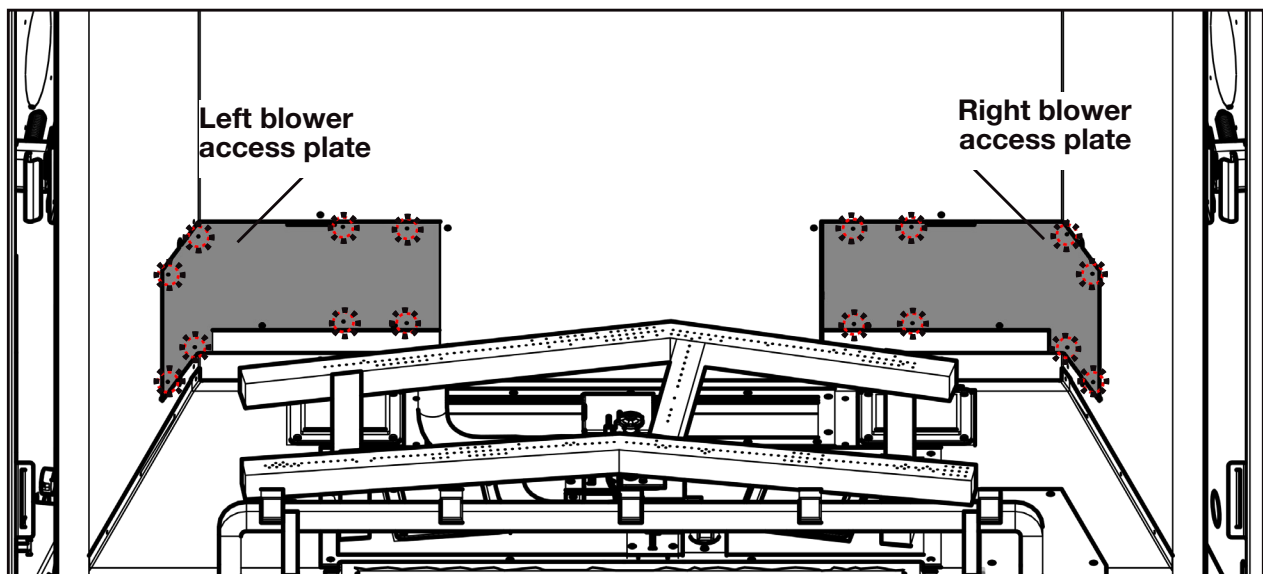
**(Fig. 2)**

G. Lift the blower up from the slots.

REAR VIEW

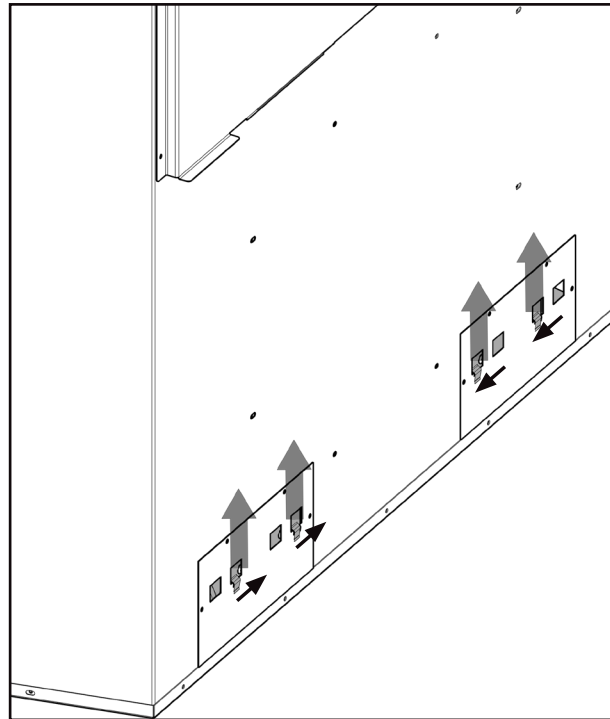

H. Rotate the blower down the side of the firebox and out of the opening. Disconnect wires.

TOP VIEW

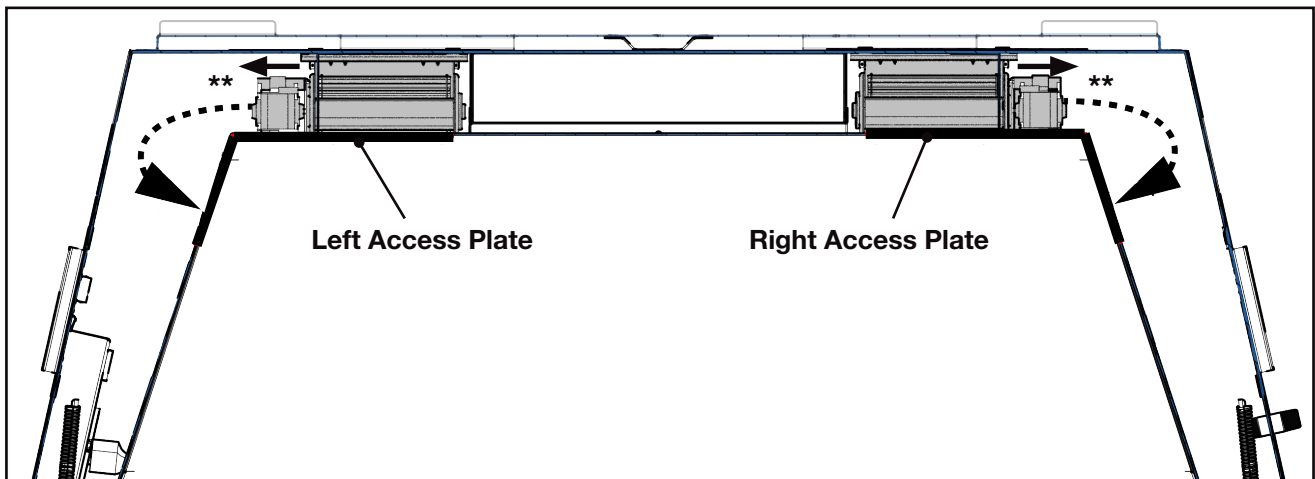

note:

Ensure the blower motor is on the correct side. **

Some components have been hidden for clarity.

I. Replace the blower assembly and reverse previous steps.

Drywall dust will penetrate into the blower bearings, causing irreparable damage. Care must be taken to prevent drywall dust from coming into contact with the blower or its compartment. Any damage resulting from this condition is not covered by the warranty policy.

11.0 replacement parts

WARNING

- Failure to position the parts in accordance with this manual or failure to use only parts specifically approved with this appliance may result in property damage or personal injury.

Contact your dealer for questions concerning prices and policies on replacement parts. Normally, all parts can be ordered through your Authorized dealer / distributor.

For warranty replacement parts, a photocopy of the original invoice will be required to honour the claim.

When ordering replacement parts always give the following information:

- Model & Serial Number of appliance
- Installation date of appliance
- Part number
- Description of part
- Finish

Parts, part numbers, and availability are subject to change without notice.

Parts identified as stocked will be delivered within 2 to 5 business days for most delivery destinations.

Parts not identified as stocked will be delivered within a 2 to 4 week period, for most cases.

Parts identified as 'SO' are special order and can take up to 90 days for delivery.

11.1 EX36 overview

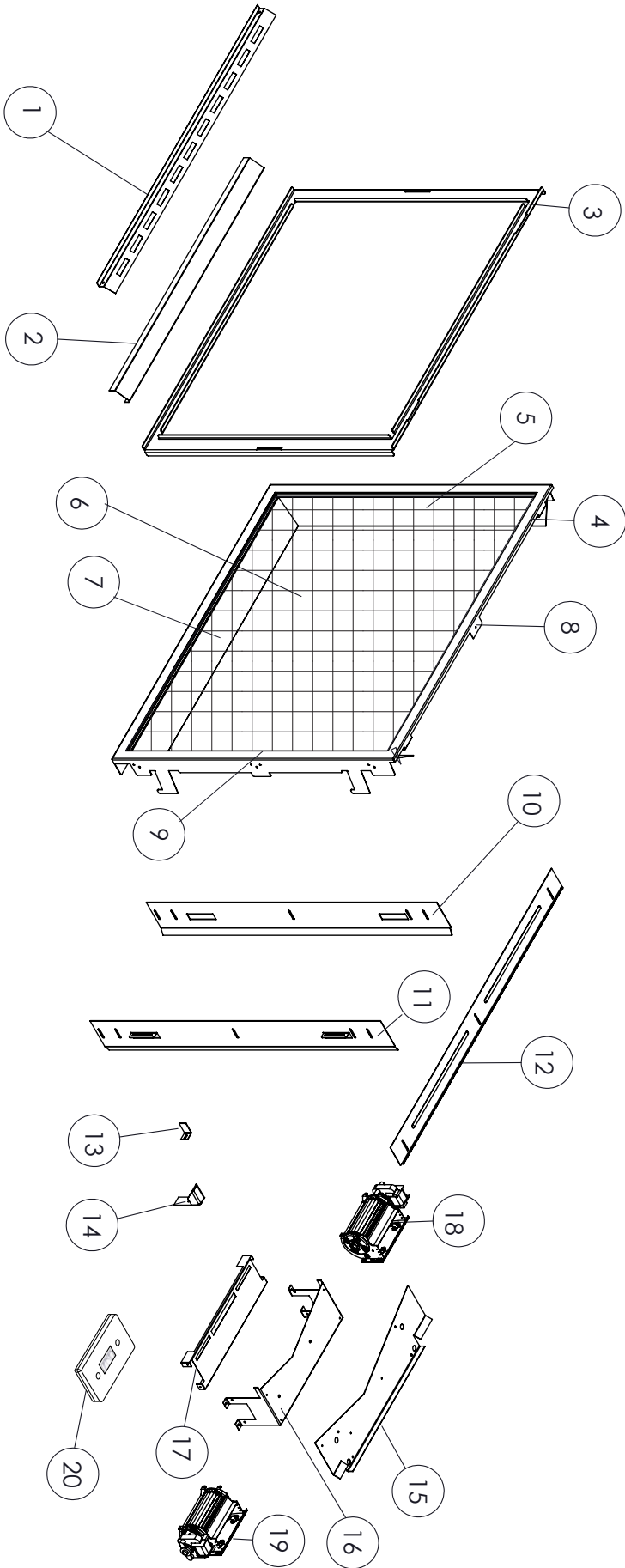

Items may not appear exactly as illustrated.

Ref. No	Part Number	Part Description	Stocked
1	W585-0961-SER	Light shield	
2	W715-1234-SER	Door trim	
3	W010-4617-SER	Complete door assembly	Yes
4	W010-4616-SER	Premium safety barrier assembly	Yes
5	W350-0937-BK1FT-SER	Left side safety barrier	
6	W565-0326-SER	Premium safety screen	
7	W350-0922-BK1FT-SER	Top/bottom safety barrier	
8	W475-1707-BK1FT-SER	Safety barrier front	
9	W350-0923-BK1FT-SER	Right side safety barrier	
10	W525-0085-SER	Left finishing guide	

Ref. No	Part Number	Part Description	Stocked
11	W525-0084-SER	Right finishing guide	
12	W525-0083-SER	Upper finishing guide	
13	W500-0264-SER	Brick retainer	Yes
14	W655-0938-SER	Door support	
15	W655-0933-SER	Log support top (NG)	
15	W655-0958-SER	Log support top (P)	
16	W655-0926-SER	Log support (NG)	
16	W655-0957-SER	Log support (P)	
17	W200-0788-SER	Air inlet cover	
18	W010-4624-SER	Left side blower assembly	Yes
19	W010-4623-SER	Right side blower assembly	Yes
20	W200-0405	Battery cover	Yes

replacement parts

11.2 EX36 valve train assembly

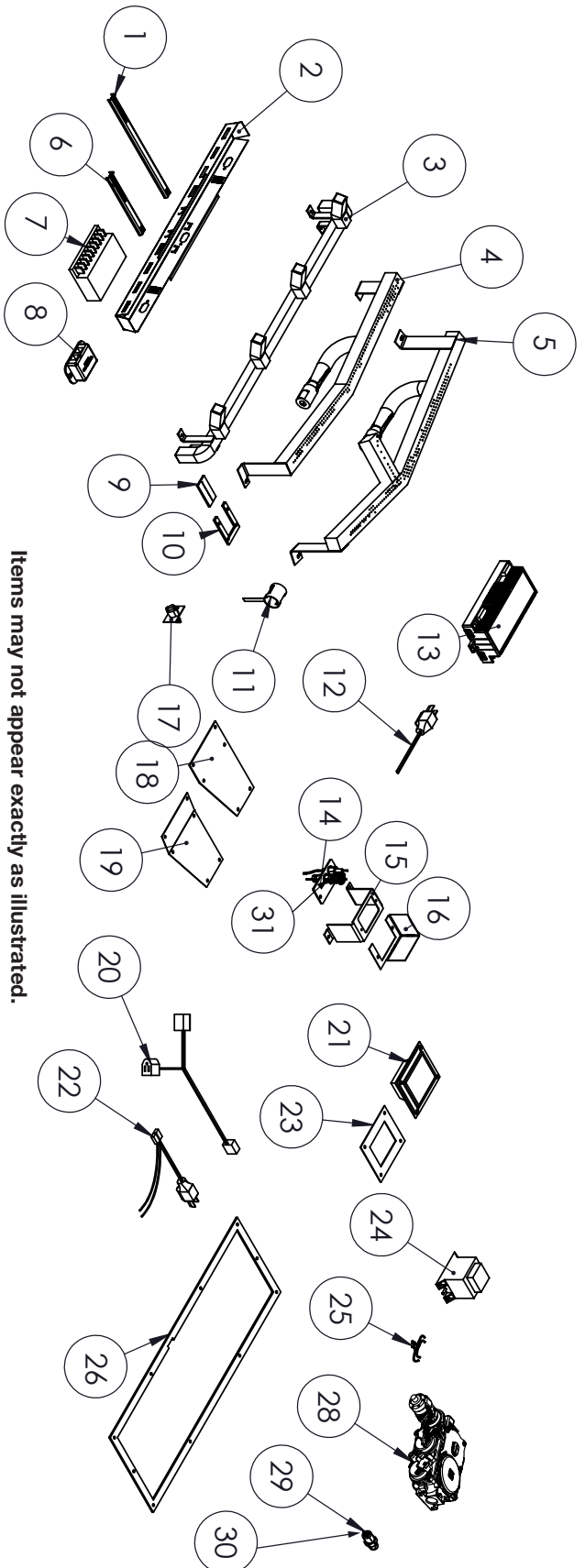

Items may not appear exactly as illustrated.

Ref. No	Part Number	Part Description	Stocked
1	W325-0105-SER	Rear air shutter handle	
2	W080-1944-SER	Halogens bracket	
3	W010-4580-SER	Grate assembly	Yes
4	W100-0256-SER	Front burner (NG)	Yes
5	W100-0285-SER	Front burner (P)	Yes
6	W100-0257-SER	Rear burner (NG)	Yes
7	W100-0286-SER	Rear burner (P)	Yes
8	W325-0104-SER	Front air shutter handle	
9	W190-0156-SER	Ember bed halogen control	
10	W190-0090	Bluetooth™ Control Module (PF2)	
11	W290-0908	Silicone gasket (adjustable shutter)	
12	W500-1046	Shutter base plate	
13	W010-4626-SER	Air shutter assembly	
14	W750-0294	18" power cord wire (PF2)	
15	W190-0177-SER	Control board (PF2 7-Day)	
16	W010-4584-SER	Pilot assembly (NG)	
17	W010-4584-SER	Pilot assembly (NG)	
18	W010-4586-SER	Pilot assembly (P)	
19	W080-1943-SER	Pilot bracket	
20	W585-0960-SER	Pilot shield	

Ref. No	Part Number	Part Description	Stocked
17	W010-4608-SER	Light assembly (w/ plate)	
18	W290-0904	Valve access gasket	
19	W500-1024-SER	Access plate	
20	W750-0358	Female pig tails w/ connector (PF2)	Yes
21	W405-0094-SER	Light assembly	
22	W750-0478	Blower wire harness	
23	W290-0080	1/8" Kaowool gasket	Yes
24	W707-0019	Transformer	Yes
25	W750-0479	Night Light™ wire harness	
26	W290-0902	Valve train gasket	
27*	W370-0219	Bulb/lamp replacement kit	
28	W725-0056	Valve (NG)	
28	W725-0057	Valve (P)	
29	W456-0051	Front burner orifice #51 (NG)	
29	W456-0057	Front burner orifice #57 (P)	
30	W456-0041	Rear burner orifice #41 (NG)	
30	W456-0054	Rear burner orifice #54 (P)	
31	W455-0070	Pilot orifice #62 (NG)	
31	W455-0068	Pilot orifice #35 (P)	

11.3 EX36 logs

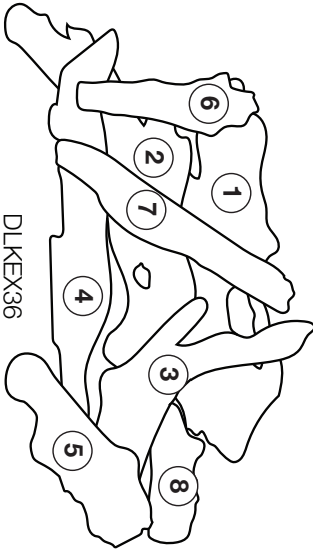

Ref. No	Part Number	Part Description	Stocked
1	W135-0883	#1 Rear log	
2	W135-0884	#2 Left middle	
3	W135-0885	#3 Right middle	
4	W135-0886	#4 Front log	
5	W135-0887	#5 Front right log	
6	W135-0888	#6 Left crossover log	
7	W135-0889	#7 Middle crossover log	
8	W135-0890	#8 Right crossover log	

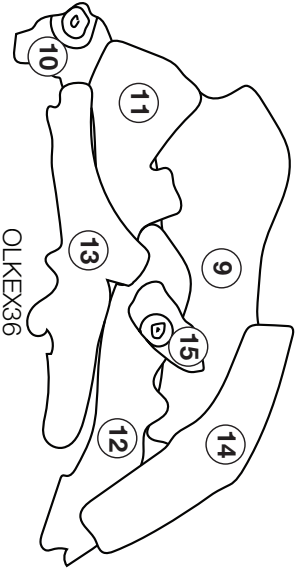

Ref. No	Part Number	Part Description	Stocked
9	W135-0867	#1 Rear log	
10	W135-0868	#2 Left middle log	
11	W135-0869	#3 Middle middle log	
12	W135-0870	#4 Right middle log	
13	W135-0871	#5 Front log	
14	W135-0872	#6 Right crossover log	
15	W135-0873	#7 Middle crossover log	

Items may not appear exactly as illustrated.

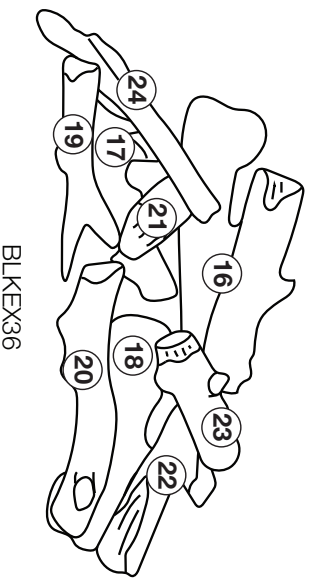

Ref. No	Part Number	Part Description	Stocked
16	W135-0942	#1 Rear log	
17	W135-0943	#2 Middle left log	
18	W135-0944	#3 Middle right log	
19	W135-0945	#4 Front left log	
20	W135-0946	#5 Front right log	
21	W135-0947	#6 Bottom left log	
22	W135-0948	#7 Bottom right log	
23	W135-0949	#8 Top left log	
24	W135-0950	#9 Top right log	

replacement parts

11.4 EX42 overview

Ref. No	Part Number	Part Description	Stocked
1	W585-0962-SER	Light shield	
2	W715-1233-SER	Door trim	
3	W010-4619-SER	Complete door assembly	Yes
4	W010-4618-SER	Premium safety barrier assembly	Yes
5	W350-0938-BK1FT-SER	Left side safety barrier	
6	W565-0327-SER	Premium safety screen	
7	W350-0929-BK1FT-SER	Top/bottom safety barrier	
8	W475-1730-BK1FT-SER	Safety barrier front	
9	W350-0928-BK1FT-SER	Right side safety barrier	

Ref. No	Part Number	Part Description	Stocked
10	W525-0088-SER	Left finishing guide	
11	W525-0087-SER	Right finishing guide	
12	W525-0086-SER	Upper finishing guide	
13	W500-0264-SER	Brick retainer	Yes
14	W655-0938-SER	Door support	
15	W655-0934-SER	Log support top	
16	W655-0932-SER	Log support	
17	W200-0788-SER	Air inlet cover	
18	W010-4623-SER	Right side blower assembly	Yes
19	W010-4624-SER	Left side blower assembly	Yes
20	W200-0405	Battery cover	

Items may not appear exactly as illustrated.

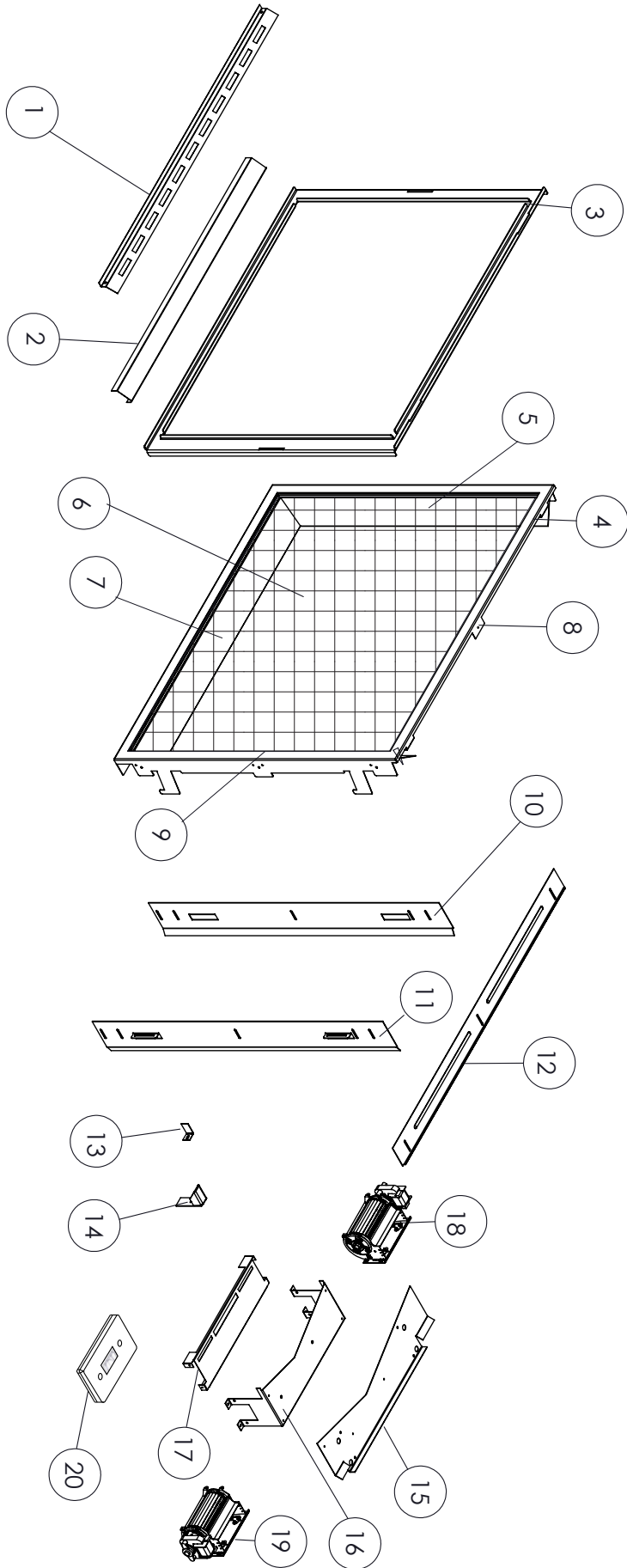

11.5 EX42 valve train assembly

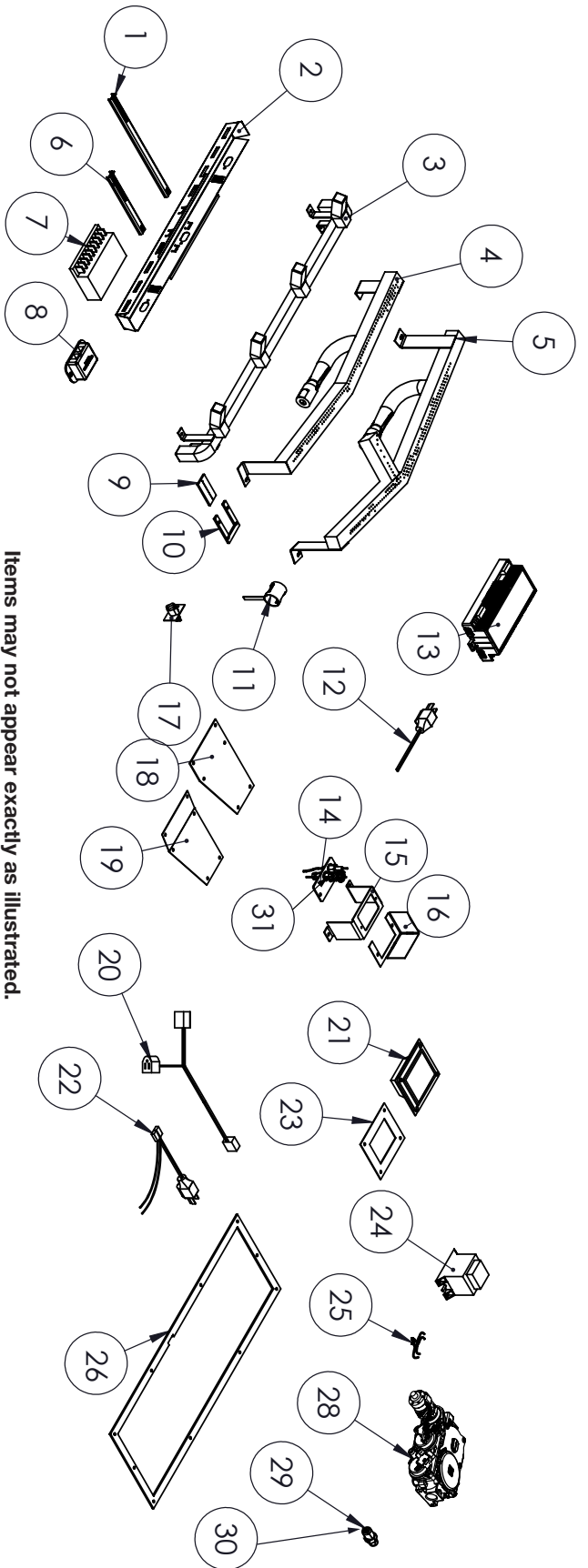

Items may not appear exactly as illustrated.

Ref. No	Part Number	Part Description	Stocked
1	W325-0105-SER	Rear air shutter handle	
2	W080-1944-SER	Halogens bracket	
3	W010-4593-SER	Grate assembly	Yes
4	W100-0258-SER	Front burner (NG)	Yes
4	W100-0281-SER	Front burner (P)	Yes
5	W100-0259-SER	Rear burner (NG)	Yes
5	W100-0282-SER	Rear burner (P)	Yes
6	W325-0104-SER	Front air shutter handle	
7	W190-0156-SER	Ember bed halogen control	
8	W190-0090	Bluetooth™ Control Module (PF2)	
9	W290-0908	Silicone gasket (adjustable shutter)	
10	W500-1046	Shutter base plate	
11	W010-4626-SER	Air shutter assembly	
12	W750-0294	18" power cord wire (PF2)	
13	W190-0177-SER	Control board (PF2 7-Day)	
14	W010-4584-SER	Pilot assembly (NG)	
14	W010-4586-SER	Pilot assembly (P)	
15	W080-1943-SER	Pilot bracket	
16	W585-0960-SER	Pilot shield	

Ref. No	Part Number	Part Description	Stocked
17	W010-4608-SER	Light assembly (w/ plate)	
18	W290-0904	Valve access gasket	
19	W500-1024-SER	Access plate	
20	W750-0358	Female pig tails w/ connector (PF2)	Yes
21	W405-0094-SER	Light assembly	
22	W750-0478	Blower wire harness	
23	W290-0080	1/8" Kaowool gasket	Yes
24	W707-0019	Transformer	Yes
25	W750-0479	Night Light™ wire harness	
26	W290-0902	Valve train gasket	
27*	W370-0219	Bulb/lamp replacement kit	
28	W725-0056	Valve (NG)	
28	W725-0057	Valve (P)	
29	W456-0046	Front burner orifice #46 (NG)	
29	W456-0057	Front burner orifice #57 (P)	
30	W456-0038	Rear burner orifice #38 (NG)	
30	W456-0053	Rear burner orifice #53 (P)	
31	W455-0070	Pilot orifice #62 (NG)	
31	W455-0068	Pilot orifice #35 (P)	

replacement parts

11.6 EX42 logs

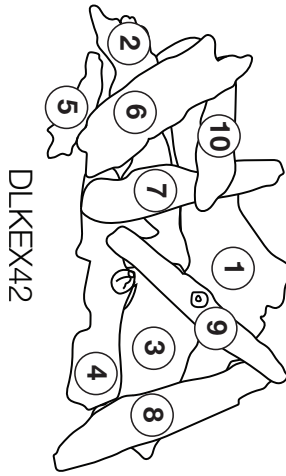

DLKEX42

Ref. No	Part Number	Part Description	Stocked
1	W135-0899	#1 Rear log	
2	W135-0900	#2 Left middle log	
3	W135-0901	#3 Right middle log	
4	W135-0902	#4 Left crossover log	
5	W135-0903	#5 Front middle log	
6	W135-0904	#6 Middle crossover log	
7	W135-0905	#7 Right crossover log	
8	W135-0906	#8 Right middle crossover log	
9	W135-0907	#9 Middle top crossover log	
10	W135-0908	#10 Front left log	

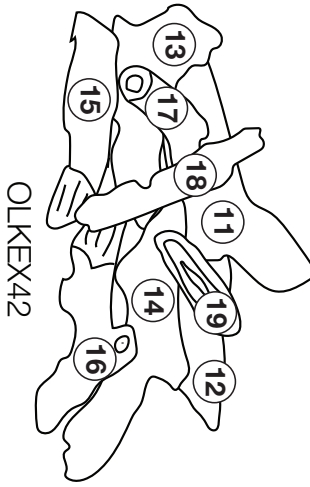

OLKEX42

Items may not appear exactly as illustrated.

Ref: No	Part Number	Part Description	Stocked
11	W135-0891	#1 Left rear log	
12	W135-0892	#2 Right rear log	
13	W135-0893	#3 Left middle log	
14	W135-0894	#4 Right middle log	
15	W135-0895	#5 Front left log	
16	W135-0896	#6 Front right log	
17	W135-0898	#7 Left middle crossover log	
18	W135-0897	#8 Left crossover log	
19	W135-0898	#9 Right crossover log	

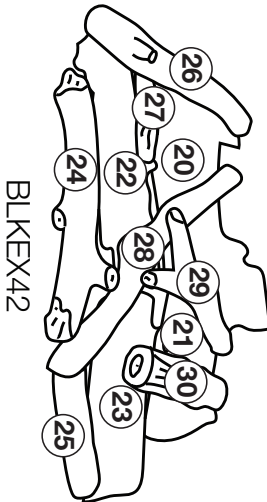

BLKEX42

Ref: No	Part Number	Part Description	Stocked
20	W135-0951	#1 Left rear log	
21	W135-0952	#2 Right rear log	
22	W135-0953	#3 Middle left log	
23	W135-0954	#4 Middle right log	
24	W135-0955	#5 Front left log	
25	W135-0956	#6 Front right log	
26	W135-0957	#7 Left crossover log	
27	W135-0958	#8 Bottom left crossover log	
28	W135-0959	#9 Middle left crossover log	
29	W135-0960	#10 Middle right crossover log	
30	W135-0961	#11 Right crossover log	

! WARNING

- Always light the pilot whether for the first time or if the gas supply has run out, with the glass door open or removed.
- Turn off gas and electrical power before servicing the appliance.
- Appliance may be hot. Do not service until appliance has cooled.
- Do not use abrasive cleaners

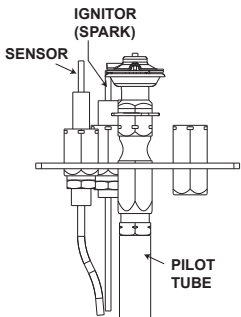
symptom	problem	test solution															
Main burner flame is a blue, lazy, transparent flame. (This is not applicable in outdoor appliances)	Blockage in vent. Incorrect installation.	<ul style="list-style-type: none"> - Remove blockage. In really cold conditions, ice buildup may occur on the terminal and should be removed as required. (To minimize this from reoccurring, the vent lengths that pass through unheated spaces (attics, garages, crawl spaces) should be wrapped with an insulated mylar sleeve). - Refer to “venting” section to ensure correct installation. 															
Flames are consistently too large or too small. Carboning occurs.	Appliance is over-fired or under-fired.	<ul style="list-style-type: none"> - Check pressure readings: Inlet pressure can be checked by turning screw (A) counter-clockwise 2 or 3 turns and then placing pressure gauge tubing over the test point. Gauge should read as described on the chart below. Check that main burner is operating on ‘HI’. Outlet pressure can be checked the same as above using screw (B). Gauge should read as described on the chart below. Check that main burner is operating on ‘HI’. After taking pressure readings, be sure to turn screws clockwise firmly to reseal. DO NOT OVER TORQUE. Leak test with a soap and water solution. 															
		<table border="1" style="width: 100%; border-collapse: collapse;"> <thead> <tr> <th style="padding: 5px;">Pressure</th> <th style="padding: 5px;">Natural Gas (inches)</th> <th style="padding: 5px;">Natural Gas (millibars)</th> <th style="padding: 5px;">Propane (inches)</th> <th style="padding: 5px;">Propane (millibars)</th> </tr> </thead> <tbody> <tr> <td style="padding: 5px;">Inlet</td> <td style="padding: 5px;">*7” (minimum 4.5”)</td> <td style="padding: 5px;">17.4mb (minimum 11.2mb)</td> <td style="padding: 5px;">13” (minimum 11”)</td> <td style="padding: 5px;">32.4mb (minimum 27.4mb)</td> </tr> <tr> <td style="padding: 5px;">Outlet</td> <td style="padding: 5px;">3.5”</td> <td style="padding: 5px;">8.7mb</td> <td style="padding: 5px;">10”</td> <td style="padding: 5px;">24.9mb</td> </tr> </tbody> </table> <p style="text-align: center; margin-top: 5px;">*Maximum inlet pressure not to exceed 13” w.c.</p>	Pressure	Natural Gas (inches)	Natural Gas (millibars)	Propane (inches)	Propane (millibars)	Inlet	*7” (minimum 4.5”)	17.4mb (minimum 11.2mb)	13” (minimum 11”)	32.4mb (minimum 27.4mb)	Outlet	3.5”	8.7mb	10”	24.9mb
Pressure	Natural Gas (inches)	Natural Gas (millibars)	Propane (inches)	Propane (millibars)													
Inlet	*7” (minimum 4.5”)	17.4mb (minimum 11.2mb)	13” (minimum 11”)	32.4mb (minimum 27.4mb)													
Outlet	3.5”	8.7mb	10”	24.9mb													
	Air shutter improperly adjusted.	<ul style="list-style-type: none"> - Return air shutter to specified opening, see “venturi adjustments” section in the installation manual. 															
Carbon is being deposited on glass, logs, rocks, media, or combustion chamber surfaces.	Air shutter is blocked. Flame is impinging on the glass, logs, rocks, media or combustion chamber.	<ul style="list-style-type: none"> - Ensure air shutter opening is free of lint or other obstructions. - Ensure the media is positioned correctly in the appliance. - Open air shutter to increase the primary air. - Check the input rate: check the manifold pressure and orifice size as specified by the rating plate. - Ensure door gaskets are not broken or missing and the seal is tight. - Ensure vent liners are free of holes and well sealed at all joints. - Check that minimum rise per foot (meters) has been adhered to for any horizontal venting. 															
White / grey film forms.	Sulphur from fuel is being deposited on glass, logs, or combustion chamber surfaces.	<ul style="list-style-type: none"> - Clean the glass with a recommended gas fireplace glass cleaner. DO NOT CLEAN GLASS WHEN HOT. - If deposits are not cleaned off regularly, the glass may become permanently marked. 															
Exhaust fumes smelled in room, headaches.	Appliance is spilling. (This is not applicable in outdoor appliances).	<ul style="list-style-type: none"> - Check door seal. - Check for exhaust damage. - Check that venting is installed correctly. - Room is in negative pressure; increase fresh air supply. 															

symptom	problem	test solution
Pilot will not spark.	High limit switch tripped (DHM/DHC/DHC+).	- Reset the high limit switch by pressing the button on the back of the
Pilot will not light. Makes noise with no spark at pilot burner.	Wiring: short, loose, or damaged connections (poor flame rectification).	- Verify the thermocouple/sensor is clean and the wiring is undamaged. - Verify the interrupter block is not damaged or too tight. Verify connections from pilot assembly are tight; also verify the connections are not grounding out to any metal. (Remember, the flame carries the rectification current, not the gas. If flame lifts from pilot hood, the circuit is broken. A wrong orifice or too high of an inlet pressure can cause the pilot flame to lift)*. The sensor rod may need cleaning.
	No signal from remote with no pilot ignition.	- Reprogram receiver code. - Replace receiver.
	Poor grounding.	- Verify the valve / pilot assembly are properly grounded
	Improper switch wiring.	- Troubleshoot the system with the simplest on/off switch.
	Dirty, painted, or damaged pilot and/or dirty sensor rod.	- Clean sensor rod with a green Scotch-Brite™ pad to remove any contamination that may have accumulated. Verify continuity with multimeter with ohms set at the lowest range.
Pilot sparks but will not light.	Gas supply.	- Verify that the incoming gas line ball valve is "open". - Verify that the inlet pressure reading is within acceptable limits, inlet pressures must not exceed 13" W.C. (32.4mb).
	Out of propane gas.	- Fill the tank.
	Pilot supply line may contain air.	- Repeat ignition process several times or purge the pilot supply line.
	Incorrect wiring / grounding.	- Ensure correct polarity of wiring of thermocouple (if equipped). - Verify pilot assembly / valve are properly grounded.
	Receiver (if equipped).	- Reset program: hold reset button on receiver and wait for 2 beeps. Release after second beep. Press small flame button on remote within 20 seconds, you will hear an additional beep (this signals a successful reset). - Replace receiver.
	Valve.	- Check valve and replace if necessary (Do not to overtighten thermocouple).
Burner continues to spark and pilot lights but main burner does not light.	Short or loose connection in sensor rod.	- Verify all connections. Verify the connections from the pilot assembly are tight. Also, verify these connections are not grounding out to any metal.
	Dirty, painted, or damaged pilot assembly components.	- Clean using a green Scotch-Brite™ pad to remove any contamination that may have accumulated on the sensor rod, pilot hood, ignitor, or flame sensor. Verify continuity with multimeter with ohms set at the lowest range.
Remote wall switch is in "off" position; burner comes on.	Wall switch mounted upside down.	- Reverse.
	Remote wall switch and/or wire is grounding.	- Replace. - Check for ground (short); repair ground or replace wire.
	Faulty wire	- Replace.

symptom	problem	test solution
Remote and / or receiver is not functioning properly.	Remote controls lights but no spark or flame. (Remote is locked out).	- Reset by turning power source off then on. <div style="border: 1px solid black; padding: 2px; margin-top: 5px;">note: If back up batteries are installed, they must also be removed to re-program</div>
	Receiver or remote has low battery.	- Replace batteries.
	Appliance functions but does not respond to receiver / remote	- Ensure appliance is being operated by the same device that turned it on. Remote controls function if appliance was turned on by remote. Receiver controls function if appliance was turned on by receiver.
	Error with synchronizing.	- Reset receiver and remote.
	Remote too far away from receiver.	- Refer to "wiring diagram" section.
	Wire connector pins are bent.	- Straighten pins.
	Valve wiring is damaged.	- Replace valve.
Lights or blower won't function (if equipped).	Control module switch in wrong position.	- Verify ON/OFF switch is in the "I" position which denotes on.
	COM switch is unplugged.	- Verify "COM" switch is plugged into the front of the control module.
Flames are very aggressive.	Door is ajar.	- Ensure door is secured properly.
	Venting action is too great.	- Check to ensure venting is properly sealed or restrict vent exit with restrictor plate. (Not available in all appliances).
Appliance won't perform any functions.	No power to the system.	- Check breaker to verify it's in the "on" position.
	Receiver switch in wrong position (if equipped).	- Verify that the 3 position switch on the receiver is in the remote position (middle).
	Transmitter isn't operational.	- Check battery power and battery orientation.

The following applies specifically to the SIT system only:

Pilot will not light. Makes no noise with no spark at pilot burner. (Lights and blower operate, if equipped).	Ignition box has been locked out.	Choose one of the 3 methods below to reset the system. <ol style="list-style-type: none"> 1. To reset ignition box when locked out. Turn off power supply and remove batteries (if used) from the back up battery pack. 2. To reset the DFC Board when the board goes into a lock out condition and the LED is blinking 3 times using the transmitter on/off button: <ul style="list-style-type: none"> Step 1: Turn the system off by pressing the on/off button to turn the system off. Step 2: After approximately 2 seconds press the on/off button on the transmitter again. The DFC Board will reset and the ignition sequence will start again. 3. To reset the DFC Board when the board goes into a lock out condition and the LED is blinking 3 times by cycling flame: <ul style="list-style-type: none"> Step 1: In the manual flame control mode, use the down arrow button to reduce the flame to off, indicated by the word OFF displayed on the transmitter LCD screen. Step 2: Wait approximately 2 seconds and press the up arrow button, the ignition sequence will start.
---	-----------------------------------	---

note:

Starting from **off**, press the **on** button on the transmitter. After approximately 4 seconds **on/off** button is pressed, the ignition board will start the spark. The attempt for ignition will last approximately 60 seconds. If there is no flame ignition (rectification), the board will stop sparking and the board will go into lock out.

13.0 warranty

Napoleon products are manufactured under the strict Standard of the world recognized ISO 9001 : 2015 Quality Management System.

Napoleon products are designed with superior components and materials assembled by trained craftsmen who take great pride in their work. The burner and valve assembly are leak and test-fired at a quality test station. The complete appliance is again thoroughly inspected by a qualified technician before packaging to ensure that you, the customer, receive the quality product that you expect from Napoleon.

Napoleon Gas Appliance President's Lifetime Limited Warranty

The following materials and workmanship in your new Napoleon gas appliance are warranted against defects for as long as you own the appliance. This covers: combustion chamber, heat exchanger, stainless / steel burner, Phazer™ logs and embers, rocks, ceramic glass (thermal breakage only), gold plated parts against tarnishing, porcelainized enameled components and aluminum extrusion trims.*

Electrical (110V and millivolt) components and wearable parts are covered and Napoleon will provide replacement parts free of charge during the first year of the limited warranty. This covers: blowers, gas valves, thermal switches, switches, wiring, remote controls, ignitors, gaskets and pilot assemblies.*

Labour related to warranty repair is covered free of charge during the first year (labour warranty is not applicable for the Gas Log Sets). Repair work, however, requires the prior approval of an authorized company official. Labour costs to the account of Napoleon are based on a predetermined rate schedule and any repair work must be done through an authorized Napoleon dealer.

* Construction of models vary. Warranty applies only to components included with your specific appliance.

Conditions and Limitations

Napoleon warrants its products against manufacturing defects to the original purchaser only. Registering your warranty is not necessary. Simply provide your proof of purchase along with the model and serial number to make a warranty claim. Napoleon reserves the right to have its representative inspect any product or part thereof prior to honouring any warranty claim. Provided that the purchase was made through an authorized Napoleon dealer your appliance is subject to the following conditions and limitations:

Warranty coverage begins on the date of original installation. This factory warranty is non-transferable and may not be extended whatsoever by any of our representatives. The gas appliance must be installed by a licensed, authorized service technician or contractor qualified and authorized installer, service agency or supplier. Installation must be done in accordance with the installation instructions included with the product and all local and national building and fire codes. This limited warranty does not cover damages caused by misuse, lack of maintenance, accident, alterations, abuse or neglect, and parts installed from other manufacturers will nullify this warranty. This limited warranty further does not cover any scratches, dents, corrosion or discoloring caused by excessive heat, abrasive and chemical cleaners nor chipping on porcelain enamel parts, mechanical breakage of Phazer™ logs and embers. This warranty extends to the repair or replacement of warranted parts which are defective in material or workmanship provided that the product has been operated in accordance with the operation instructions and under normal conditions. After the first year, with respect to this President's Lifetime Limited Warranty, Napoleon may, at its discretion, fully discharge all obligations with respect to this warranty by refunding to the original warranted purchaser the wholesale price of any warranted but defective part(s).

After the first year, Napoleon will not be responsible for installation, labour, or any other expenses related to the reinstallation of a warranted part and such expenses are not covered by this warranty. Notwithstanding any provisions contained in the President's Lifetime Limited Warranty, Napoleon's responsibility under this warranty is defined as above and it shall not in any event extend to any incidental, consequential or indirect damages. This warranty defines the obligations and liability of Napoleon with respect to the Napoleon gas appliance and any other warranties expressed or implied with respect to this product, its components or accessories are excluded. Napoleon neither assumes, nor authorizes any third party to assume, on its behalf, any other liabilities with respect to the sale of this product. Napoleon will not be responsible for: over-firing, downdrafts, spillage caused by environmental conditions such as rooftops, buildings, nearby trees, hills, mountains, inadequate vents or ventilation, excessive venting configurations, insufficient makeup air, or negative air pressures which may or may not be caused by mechanical systems such as exhaust fans, furnaces, clothes dryers, etc. Any damages to the appliance, combustion chamber, heat exchanger, plated trim or other components due to water, weather damage, long periods of dampness, condensation, damaging chemicals or cleaners will not be the responsibility of Napoleon.

During the first 10 years Napoleon will replace or repair the defective parts covered by the lifetime warranty at our discretion free of charge. From 10 years to life, Napoleon will provide replacement parts at 50% of the current retail price. The manufacturer may require that defective parts or products be returned or that digital pictures be provided to support the claim. Returned products are to be shipped prepaid to the manufacturer for investigation. If a product is found to be defective, the manufacturer will repair or replace such defect. Before shipping your appliance or defective components, your dealer must obtain an authorization number. Any merchandise shipped without authorization will be refused and returned to sender. Shipping costs are not covered under this warranty. Additional service fees may apply if you are seeking warranty service from a dealer. Warranty labour allowance is only for the replacement of the warranted part. Travel, diagnostic tests, shipping and other related charges are not covered by this warranty.

All specifications and designed are subject to change without prior notice due to on-going product improvements. Napoleon is a registered trademark of Wolf Steel Ltd.

NAPOLEON CELEBRATING OVER 40 YEARS OF HOME COMFORT PRODUCTS



7200, Route Transcanadienne, Montréal, Québec H4T 1A3
24 Napoleon Road, Barrie, Ontario, Canada L4M 0G8
214 Bayview Drive, Barrie, Ontario, Canada L4N 4Y8
103 Miller Drive, Crittenden, Kentucky, USA 41030
De Riemsdijk 22, 4004 LC Tiel, The Netherlands

Phone: 1-866-820-8686
napoleon.com