

Specifications

Model	BTU	Width		Height		Depth		Glass
		Actual	Framing	Actual	Framing	Actual	Framing	
BLX42	20,000	42	42 1/2	38 3/16	39 3/8	18 5/16	18 9/16	37 1/2 x 16 3/4

Dimensions

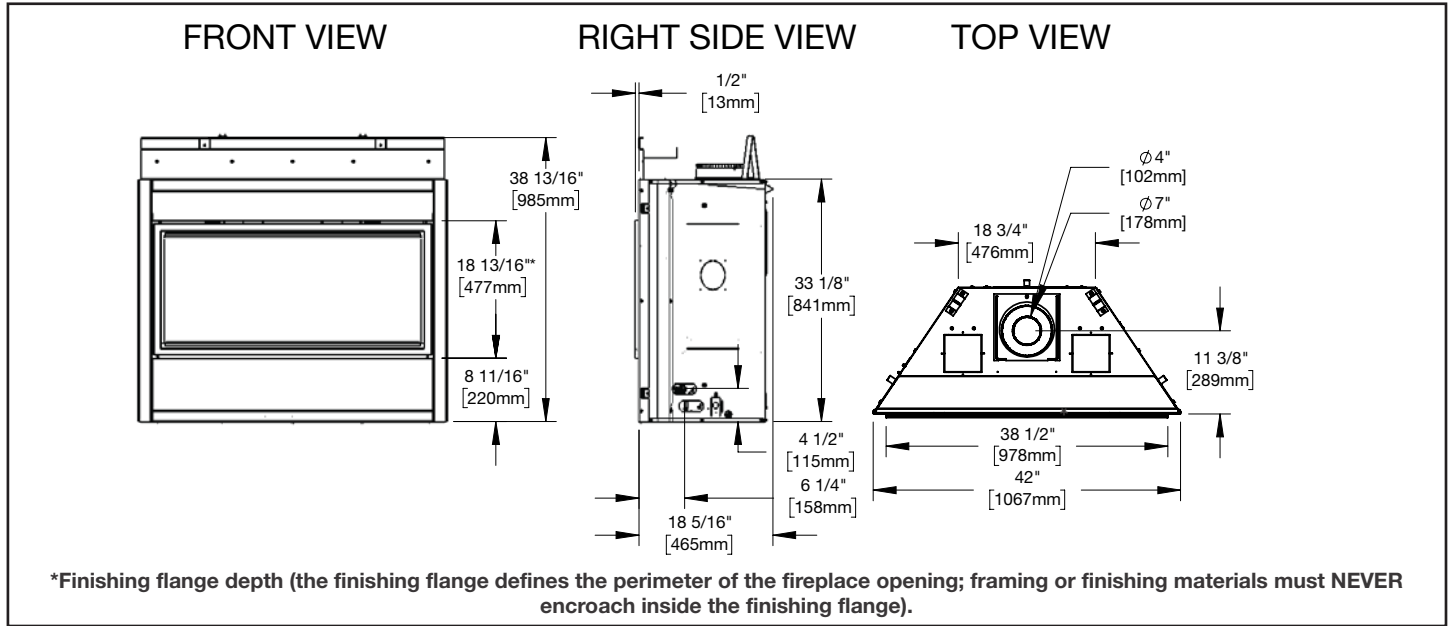

Appliance Location

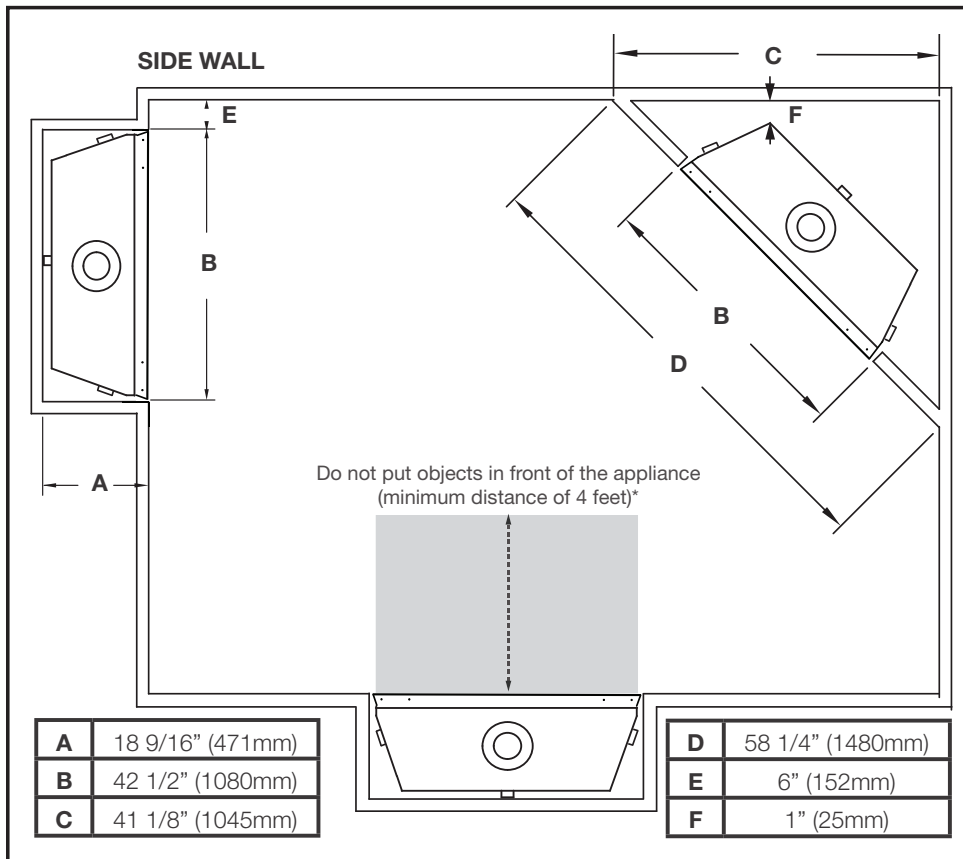

Combustible Mantel Clearances

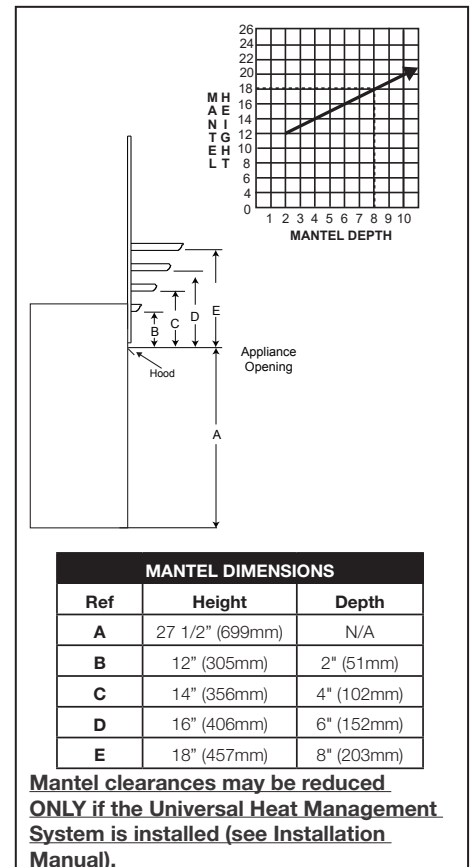

ASCENT™ LINEAR PREMIUM SERIES 42 DIRECT VENT GAS FIREPLACE



Product information provided is not complete and is subject to change without notice. Please consult the installation manual for the most up to date installation information.

Wall Penetration

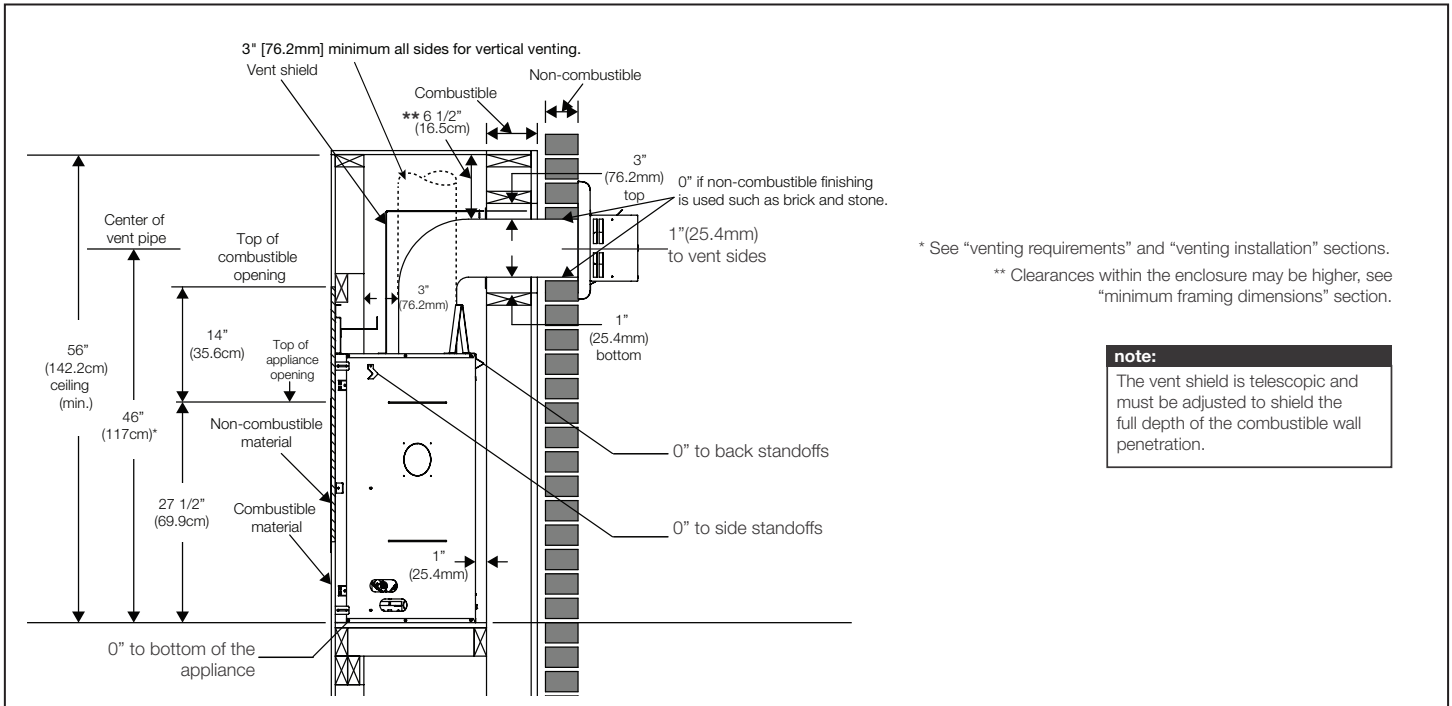

Framing

WARNING

- Do not build into this area - it must be left clear to provide adequate clearance for the vent in this 14" (35.6cm) wide area centered along the front of the appliance. The appliance should be in its final location before framing.

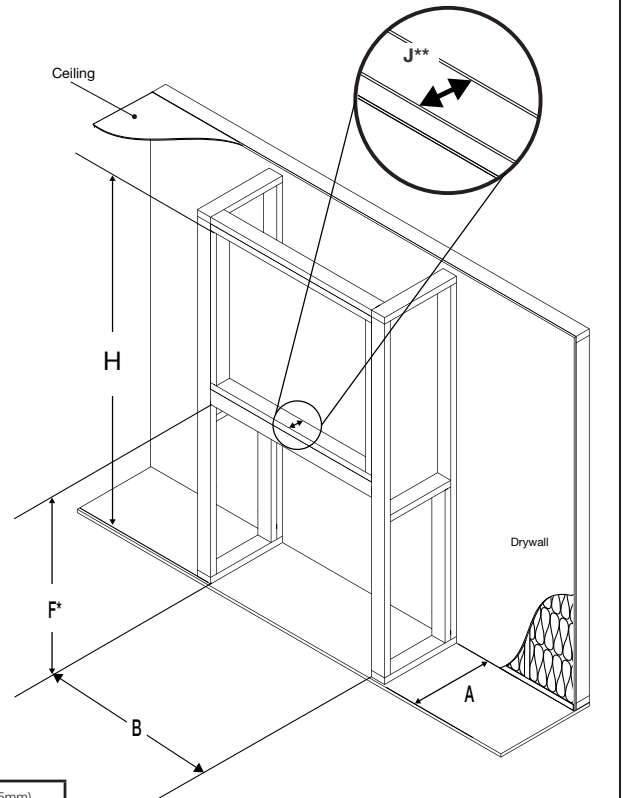
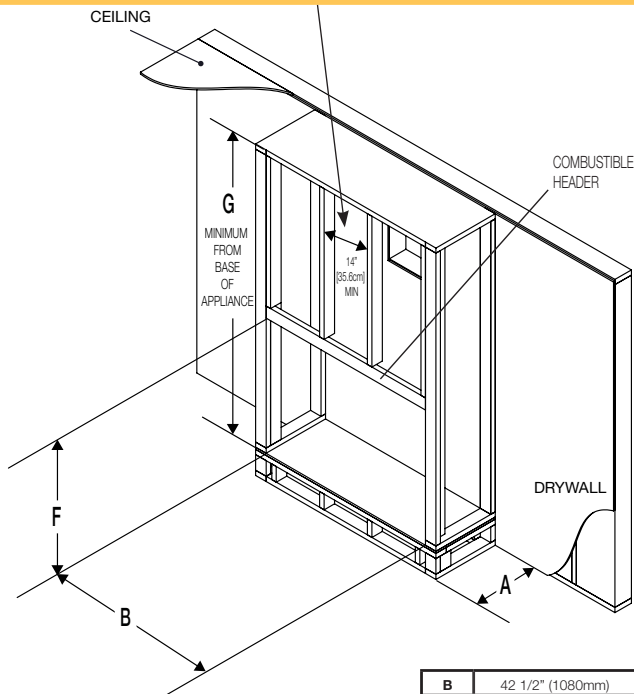

B	42 1/2" (1080mm)	H	84" (2135mm)
F	39 3/8" (1000mm)	I	3 1/2" (89mm)
A	18 9/16" (471mm)		
G	56" (1422mm)		

* Allow for finished floor and hearth thickness when setting these dimensions.
** 2" x 4" frame can be "backed" with 3/4" ply to support TV mounting hardware.

W415-10008431 / --0 / 11.14.25

Spécifications

Modèle	BTU	Largeur		Hauteur		Profondeur		Verre
		Réel	Ossature	Réel	Ossature	Réel	Ossature	
BLX42	20 000	42	42 1/2	38 3/16	39 3/8	18 5/16	18 9/16	37 1/2 x 16 3/4

Dimensions

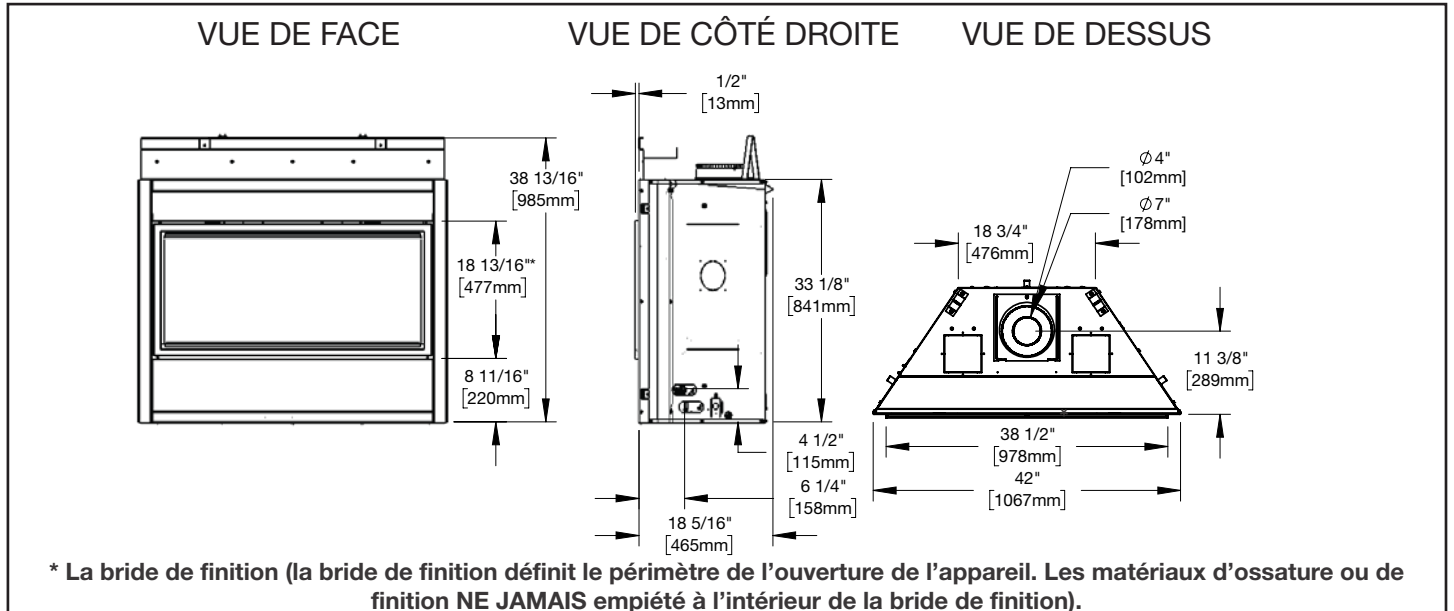

Emplacement de l'appareil

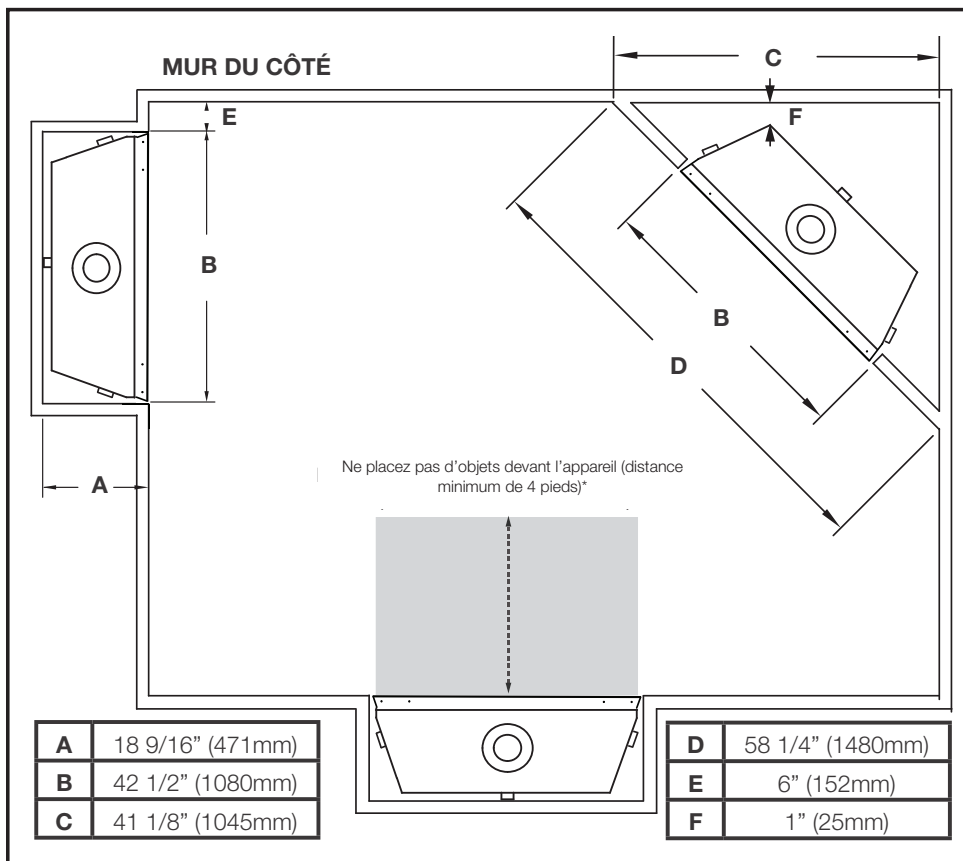

Dégagements Combustibles de la Tablette

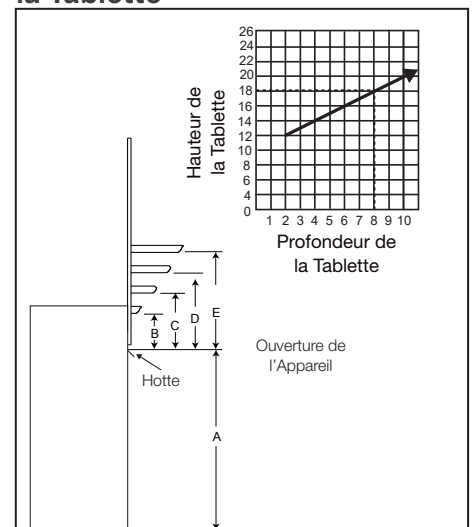

DIMENSIONS DE TABLETTE		
Réf	Hauteur	Profondeur
A	27 1/2" (699mm)	N/A
B	12" (305mm)	2" (51mm)
C	14" (356mm)	4" (102mm)
D	16" (406mm)	6" (152mm)
E	18" (457mm)	8" (203mm)

Les dégagements de la tablette peuvent être réduites SEULEMENT si la système de gestion de chaleur universelle est installée (voir la manuel d'installation).

L'information du produit fourni n'est pas complet et est sujet de changer sans préavis. Consultez le manuel d'installation pour plus d'information d'installation actuel.

Pénétration du Mur

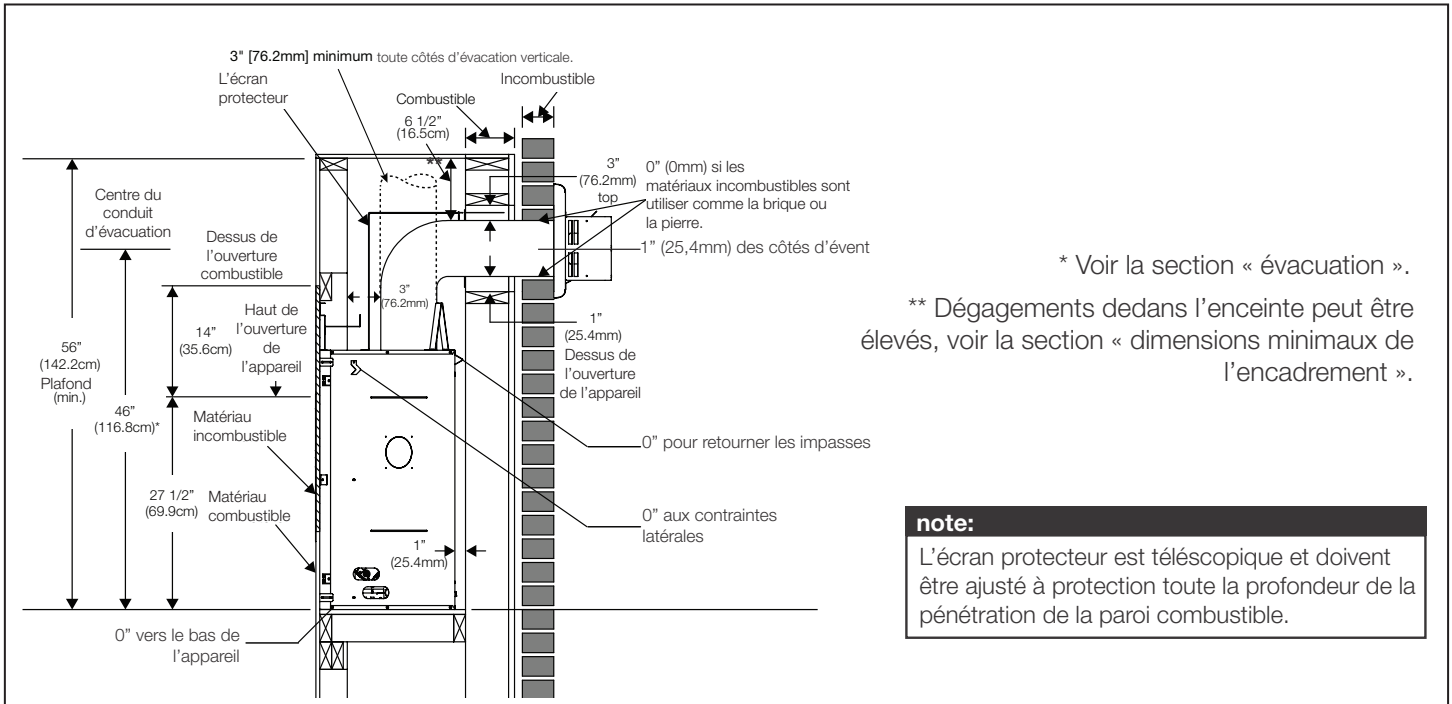

Ossature

⚠ AVERTISSEMENT

- Ne construisez pas dans cet espace de 14" (35,6cm) de largeur, centré le long de l'avant de l'appareil. Cet espace doit resté libre afin d'offrir un dégagement adéquat pour l'évacuation. Aucun matériaux combustible n'est permis.

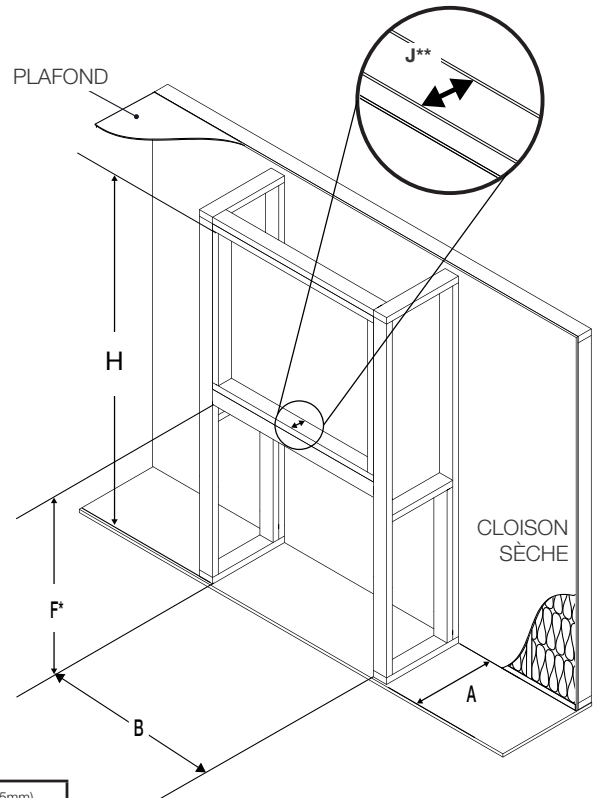
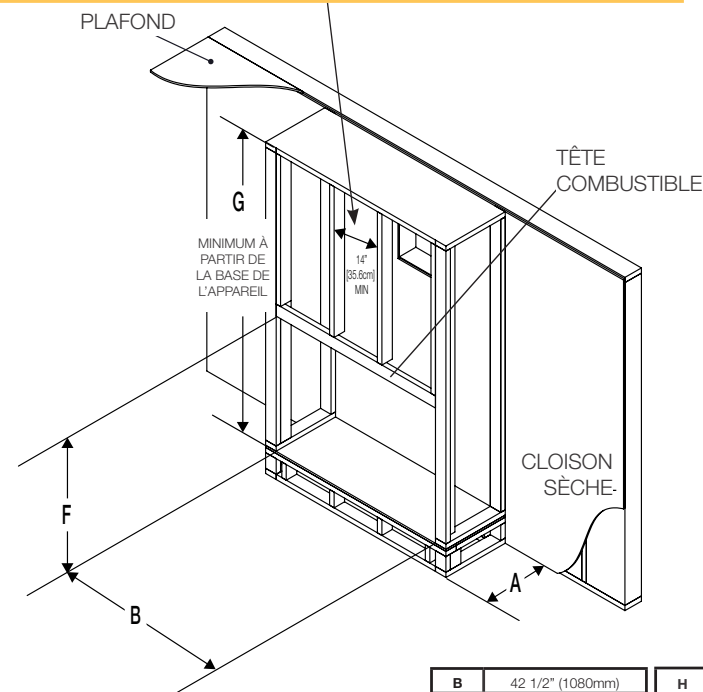

B	42 1/2" (1080mm)	H	84" (2135mm)
F	39 3/8" (1000mm)	I	3 1/2" (89mm)
A	18 9/16" (471mm)		
G	56" (1422mm)		

* Tenez compte de l'épaisseur du plancher et du foyer lorsque vous définissez ces dimensions.
** Le cadre de 2" x 4" peut être « renforcé » avec une pièce contraplâqué d'un épaisseur de 3/4" pour supporter le matériel de montage du téléviseur.

W415-10008431 / --0 / 11.14.25

Specifications

Model	BTU	Width		Height		Depth		Viewing Area
		Actual	Framing	Actual	Framing	Actual	Framing	
BLX46	24,000	46 7/8	47 3/8	39 1/16	39 3/8	18 5/16	18 9/16	14 1/8 x 39

Dimensions

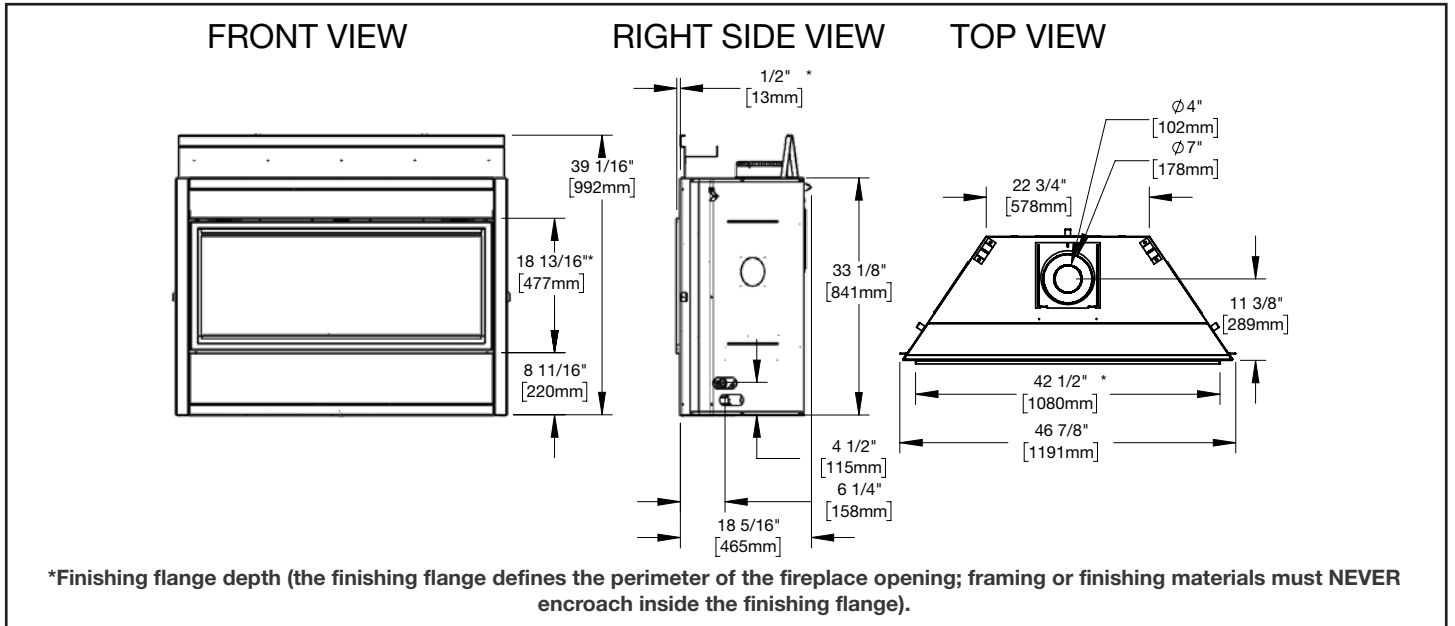

Appliance Location

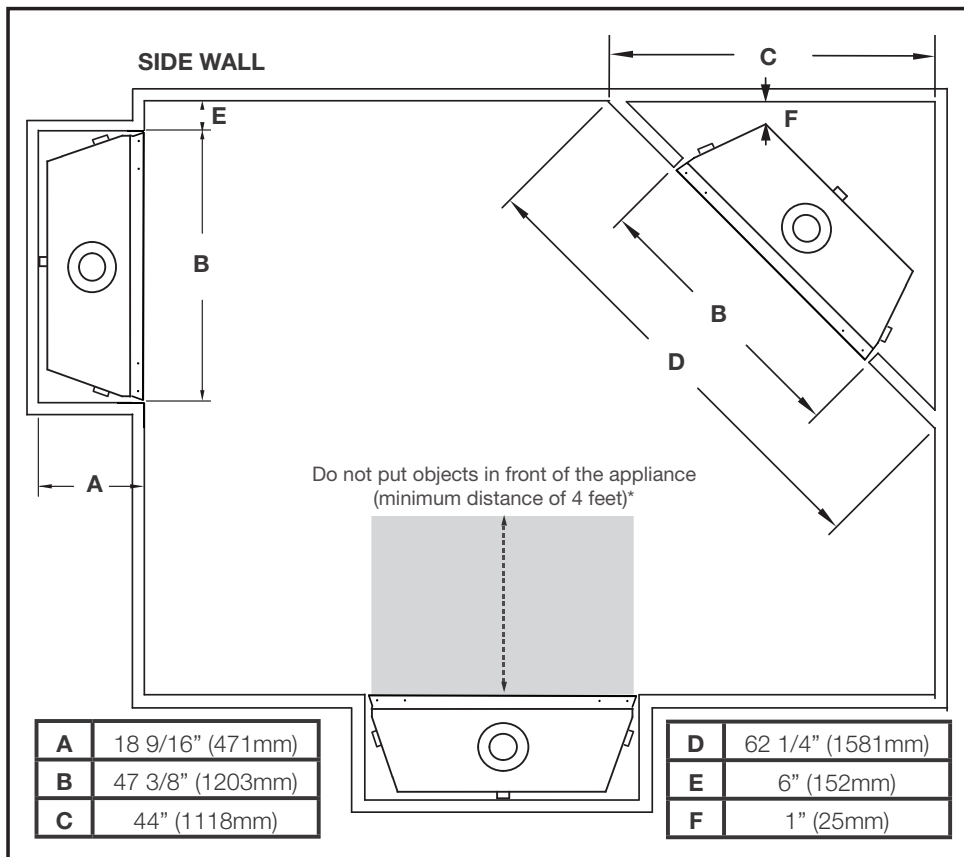

Combustible Mantel Clearances

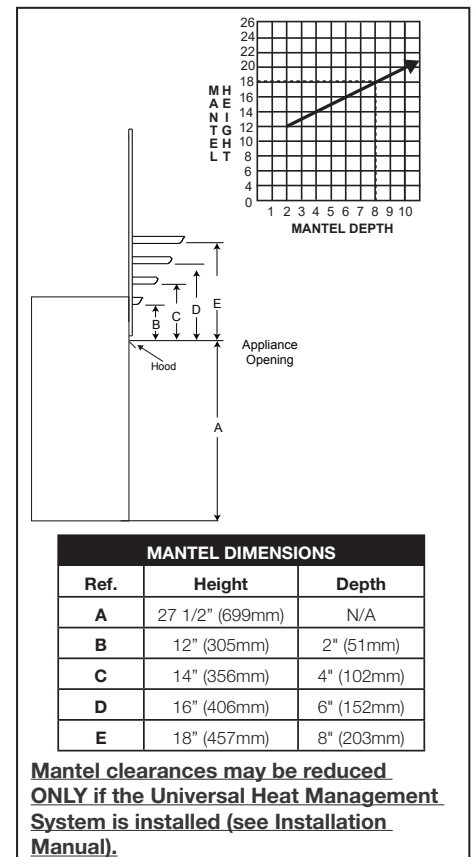

Product information provided is not complete and is subject to change without notice. Please consult the installation manual for the most up to date installation information.

Wall Penetration

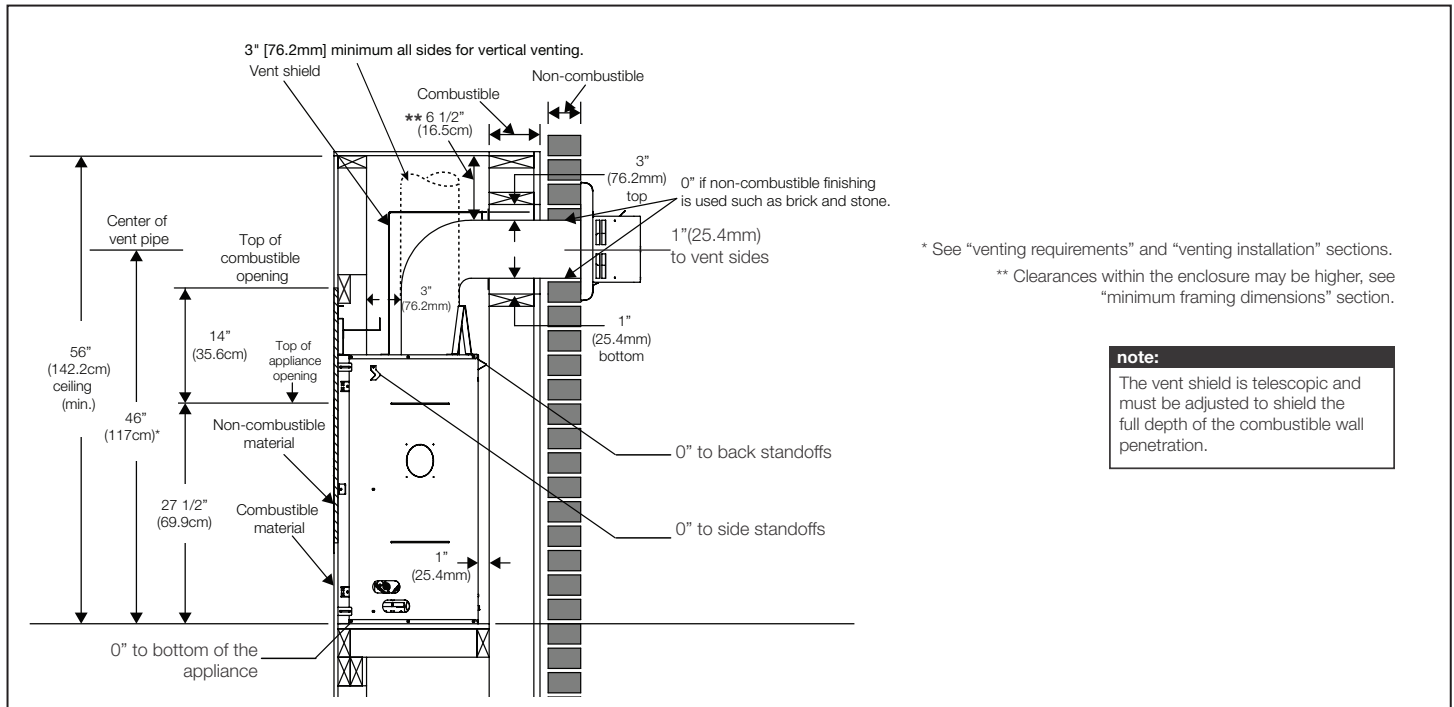

Framing

⚠ WARNING

- Do not build into this area - it must be left clear to provide adequate clearance for the vent in this 14" (35.6cm) wide area centered along the front of the appliance. The appliance should be in its final location before framing.

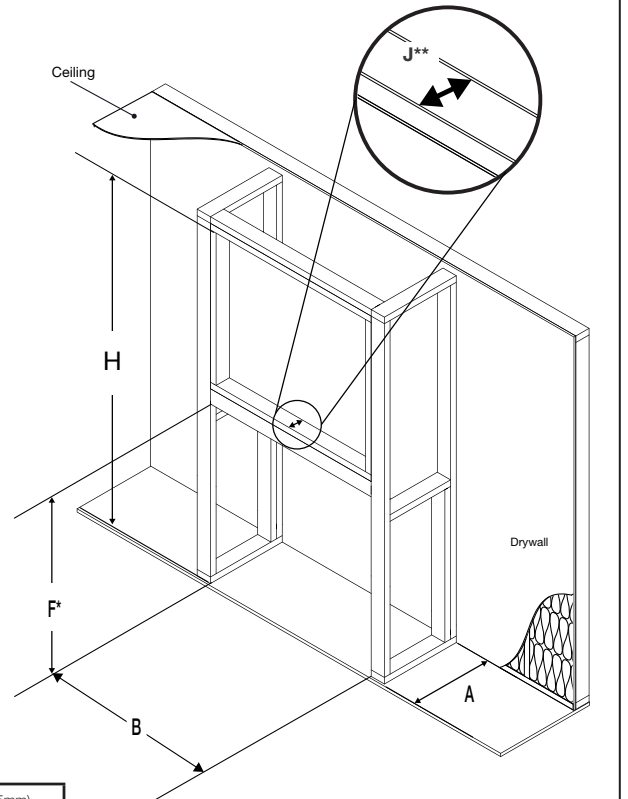
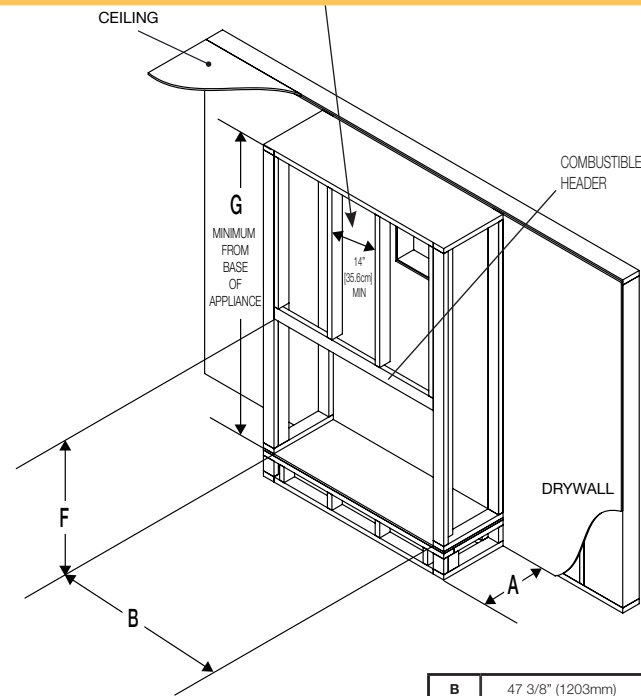

B	47 3/8" (1203mm)
F	39 3/8" (1000mm)
A	18 9/16" (471mm)
G	56" (1422mm)

H	84" (2135mm)
I	3 1/2" (89mm)

* Allow for finished floor and hearth thickness when setting these dimensions.

** 2" x 4" frame can be "backed" with 3/4" ply to support TV mounting hardware.

Spécifications

Modèle	BTU	Largeur		Hauteur		Profondeur		Dimensions de Vision
		Réel	Ossature	Réel	Ossature	Réel	Ossature	
BLX46	24,000	46 7/8	47 3/8	39 1/16	39 3/8	18 5/16	18 9/16	14 1/8 x 39

Dimensions

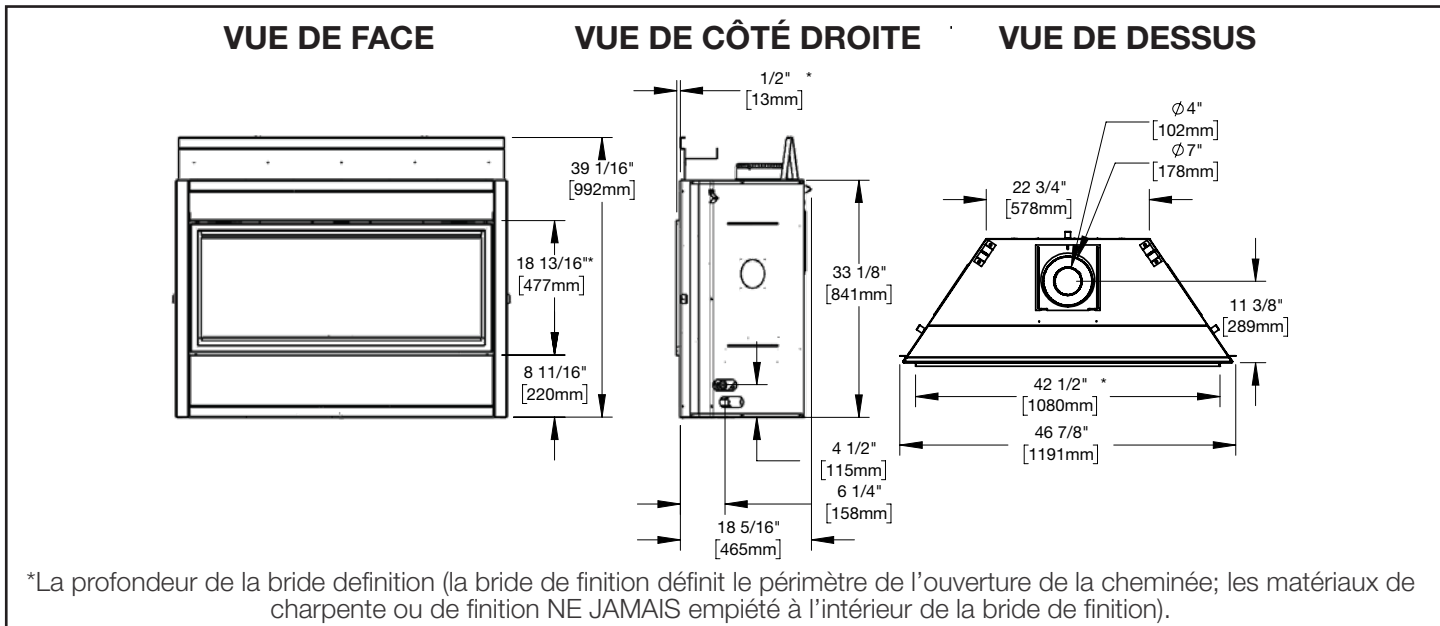

Emplacement de l'appareil

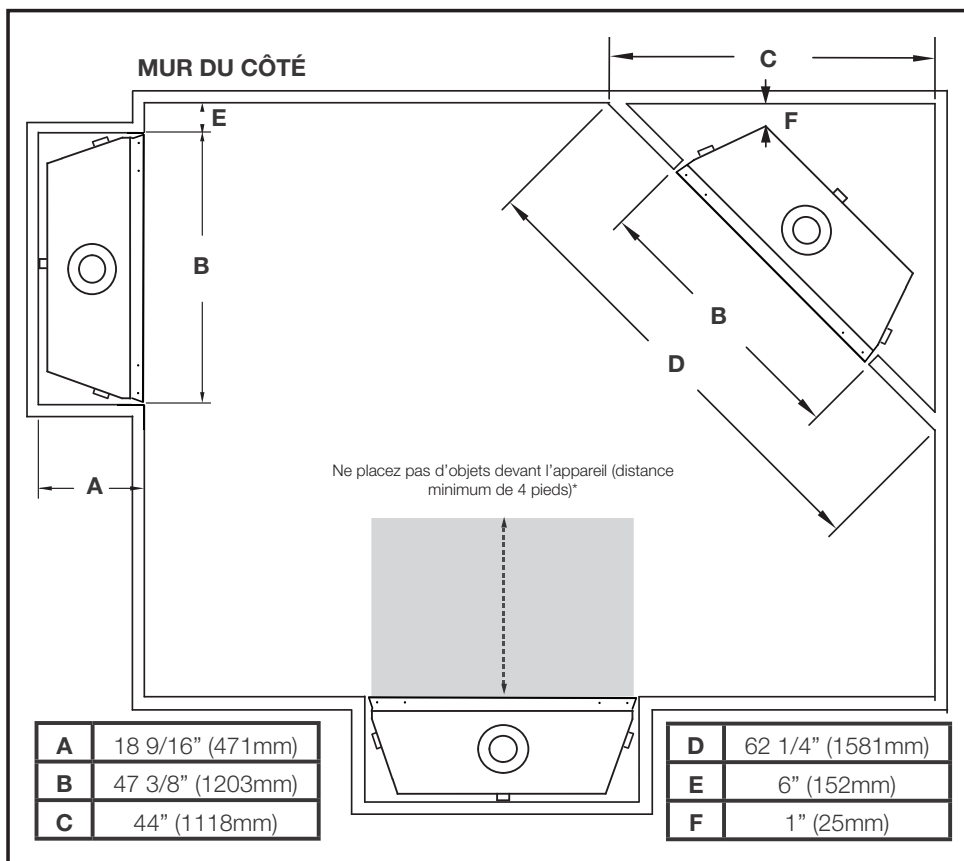

Dégagements Combustibles de la Tablette

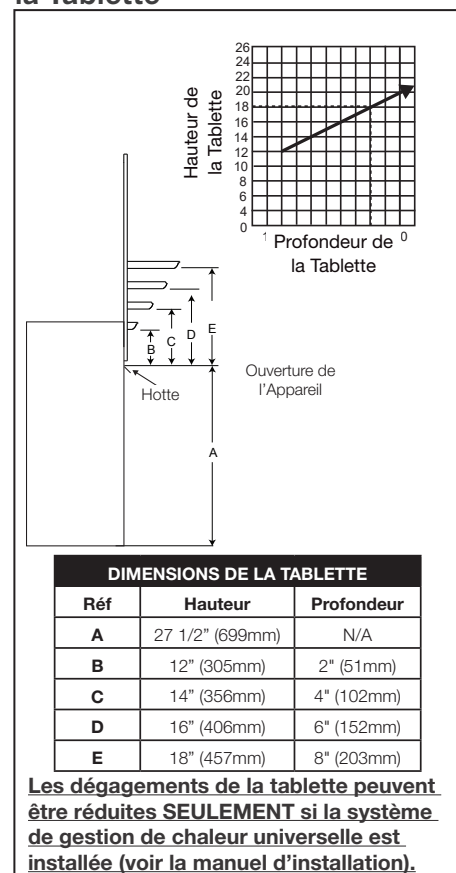

L'information du produit fourni n'est pas complet et est sujet de changer sans préavis. Consultez le manuel d'installation pour plus d'information d'installation actuel.

Pénétration du Mur

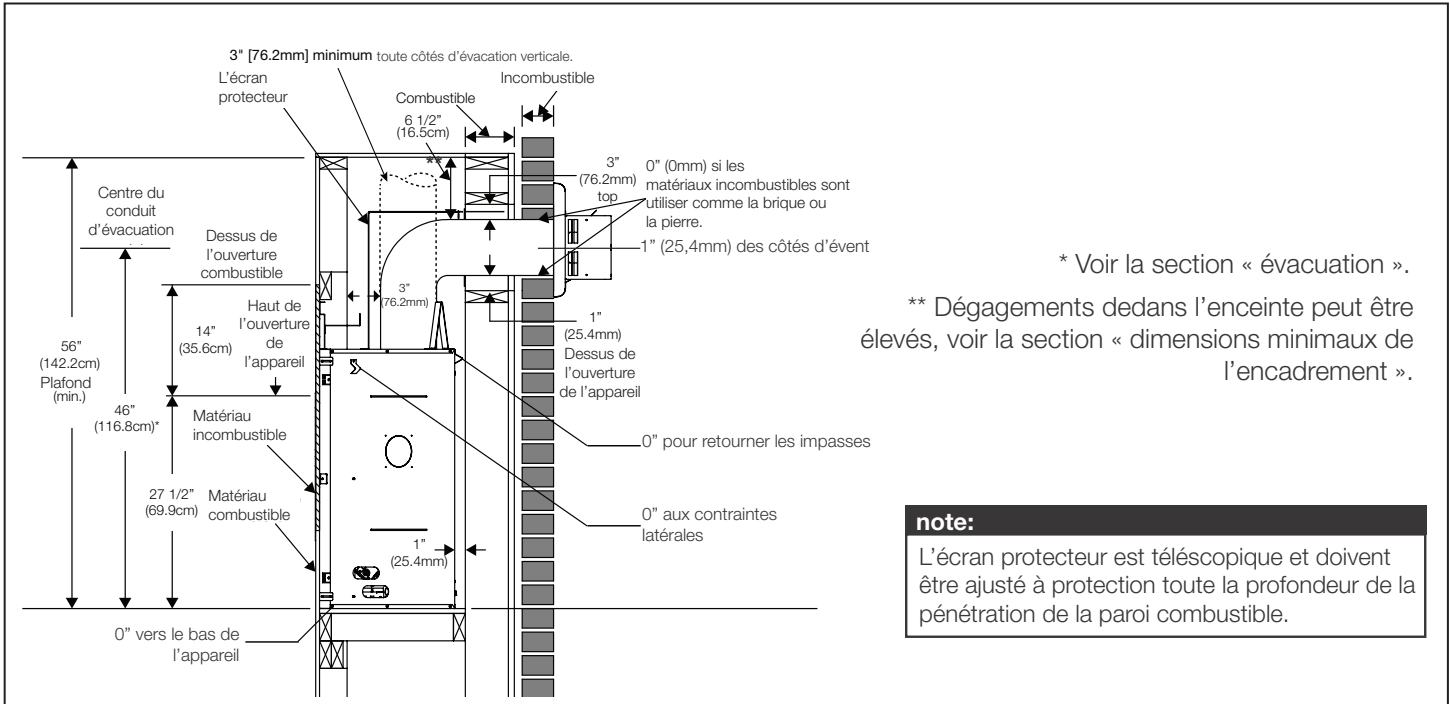

Ossature

⚠ AVERTISSEMENT

- Ne construisez pas dans cet espace de 14" (35,6cm) de largeur, centré le long de l'avant de l'appareil. Cet espace doit resté libre afin d'offrir un dégagement adéquat pour l'évacuation. Aucun matériaux combustible n'est permis.

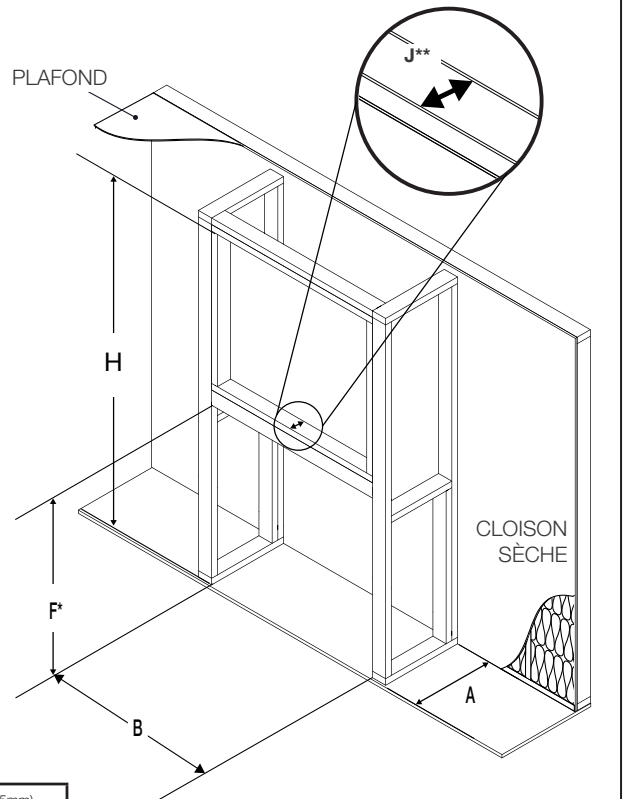
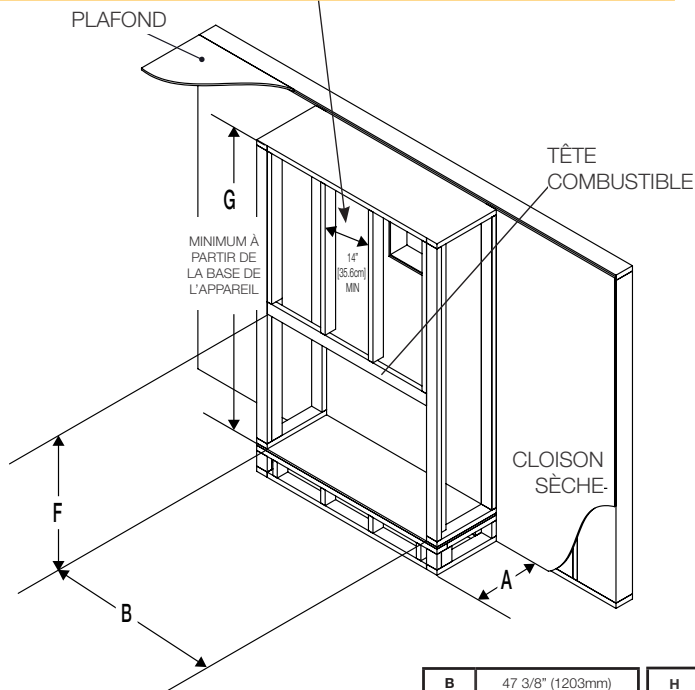

B	47 3/8" (1203mm)
F	39 3/8" (1000mm)
A	18 9/16" (471mm)
G	56" (1422mm)

H	84" (2135mm)
I	3 1/2" (89mm)

* Tenez compte de l'épaisseur du plancher et du foyer lorsque vous définissez ces dimensions.
** Le cadre de 2" x 4" peut être « renforcé » avec une pièce contreplaqué d'un épaisseur de 3/4" pour supporter le matériel de montage du téléviseur.

Specifications

Model	BTU	Width		Height		Depth		Glass
		Actual	Framing	Actual	Framing	Actual	Framing	
BLX56	28 000 (NG) 26,500 (P)	56	56 1/2	38 13/16	39 3/8	18 5/16	18 9/16	14 1/4 x 49

Dimensions

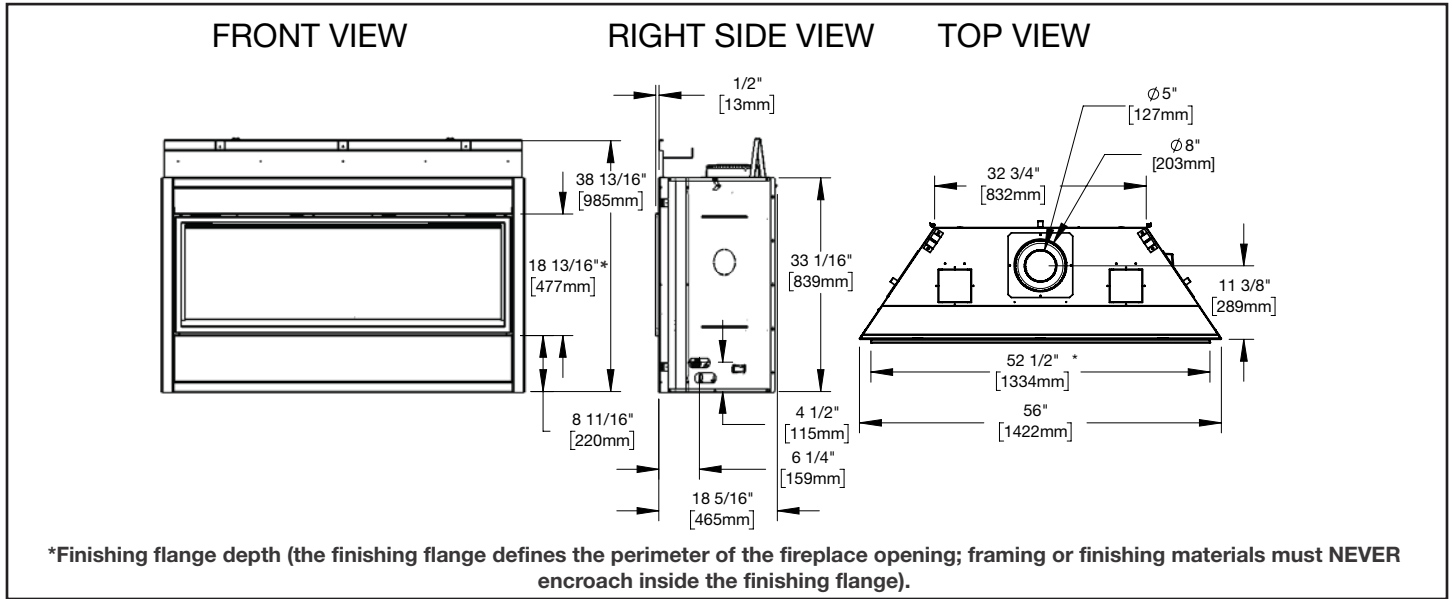

Appliance Location

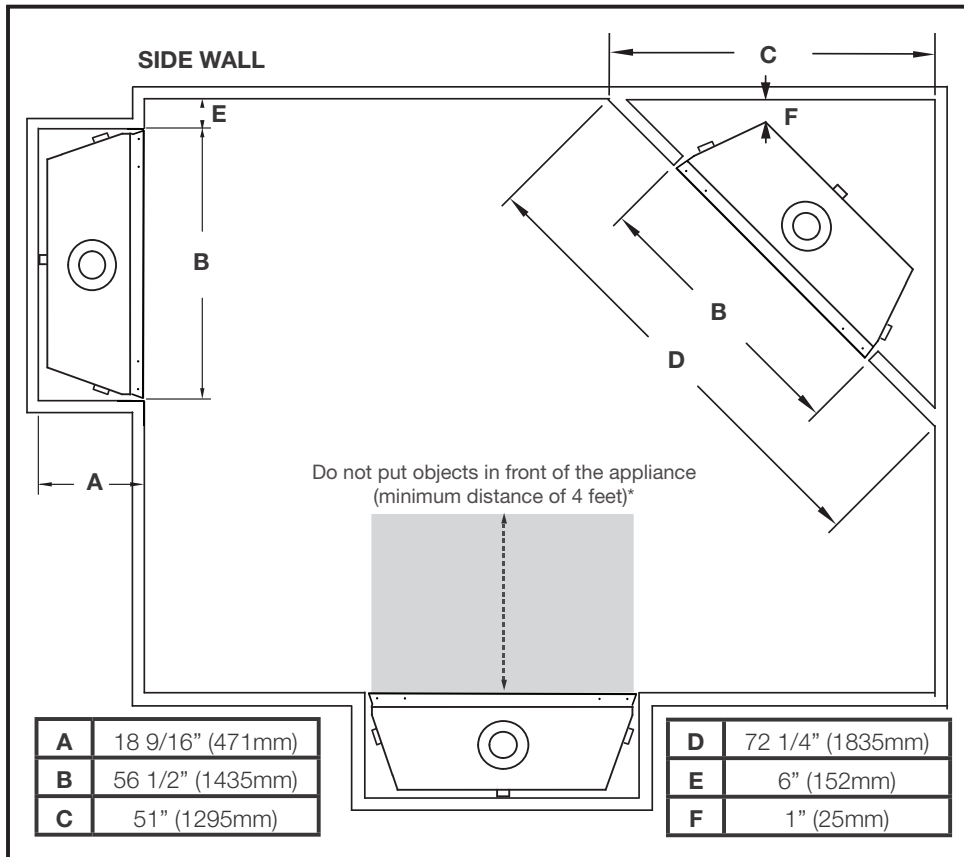

Combustible Mantel Clearances

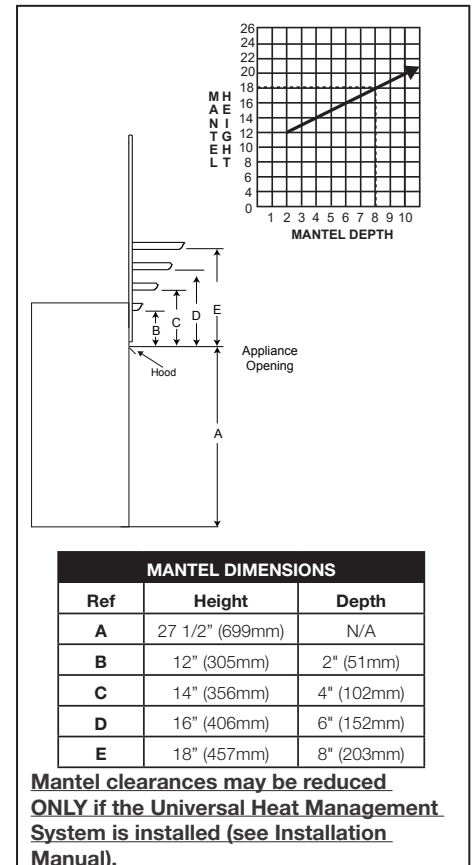

ASCENT™ LINEAR PREMIUM SERIES 56 DIRECT VENT GAS FIREPLACE



Product information provided is not complete and is subject to change without notice. Please consult the installation manual for the most up to date installation information.

Wall Penetration

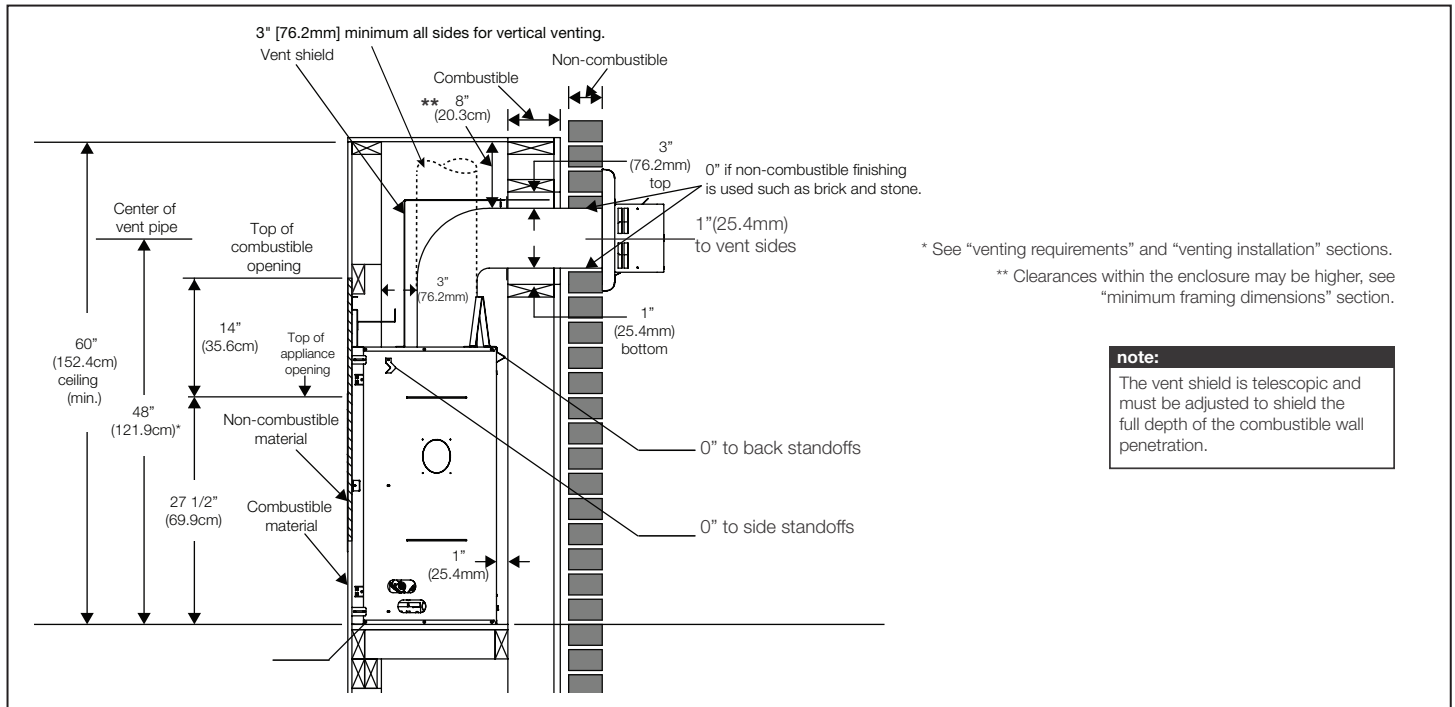

Framing

⚠ WARNING

- Do not build into this area - it must be left clear to provide adequate clearance for the vent in this 14" (35.6cm) wide area centered along the front of the appliance. The appliance should be in its final location before framing.

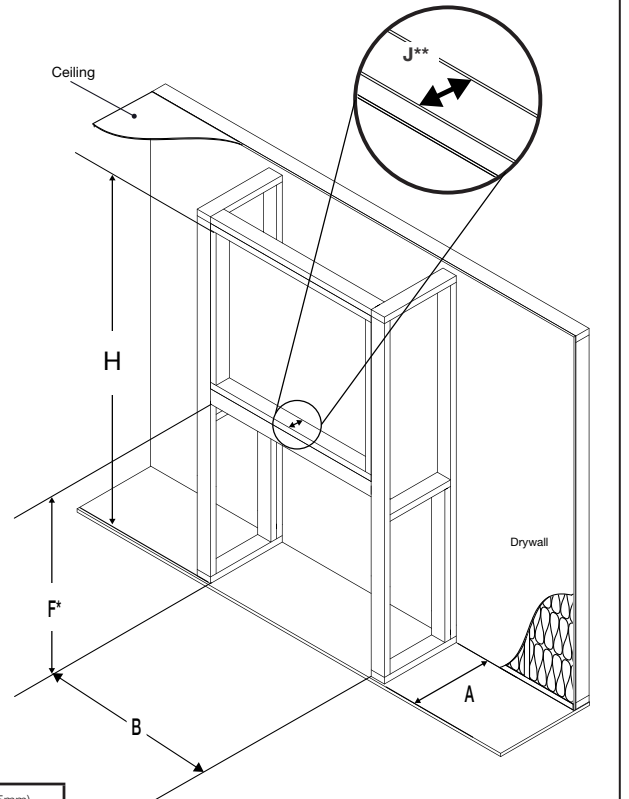
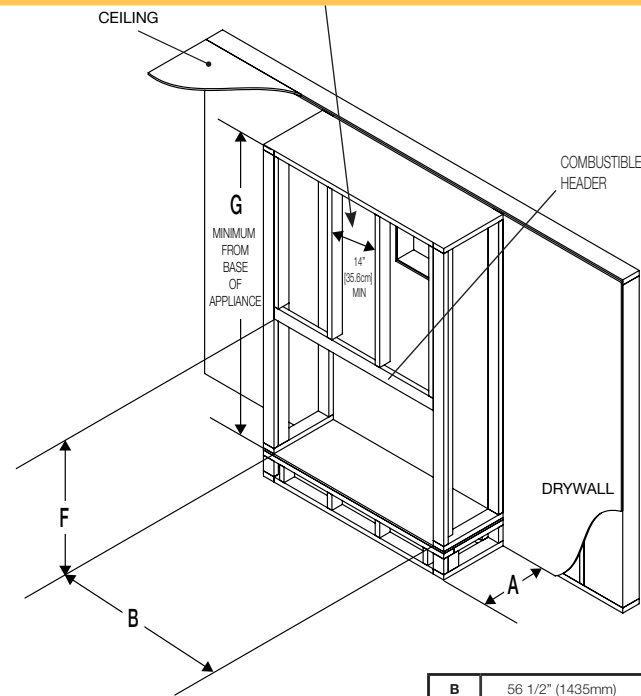

B	56 1/2" (1435mm)
F	39 3/8" (1000mm)
A	18 9/16" (471mm)
G	56" (1422mm)

H	84" (2135mm)
I	3 1/2" (89mm)

* Allow for finished floor and hearth thickness when setting these dimensions.
** 2" x 4" frame can be "backed" with 3/4" ply to support TV mounting hardware.

Spécifications

Modèle	BTU	Largeur		Hauteur		Profondeur		Dimensions de Vision
		Réel	Ossature	Réel	Ossature	Réel	Ossature	
BLX56	28 000 (NG) 26,500 (P)	56	56 1/2	38 13/16	39 3/8	18 5/16	18 9/16	14 1/4 x 49

Dimensions

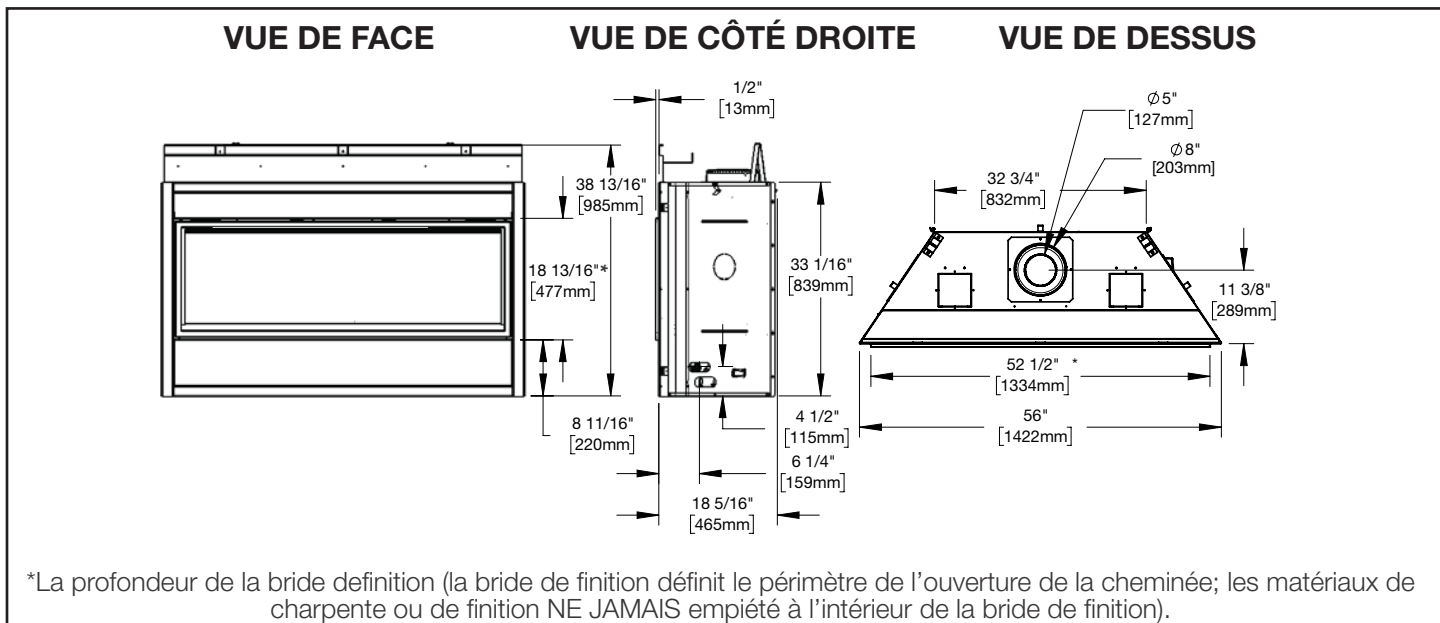

Emplacement de l'appareil

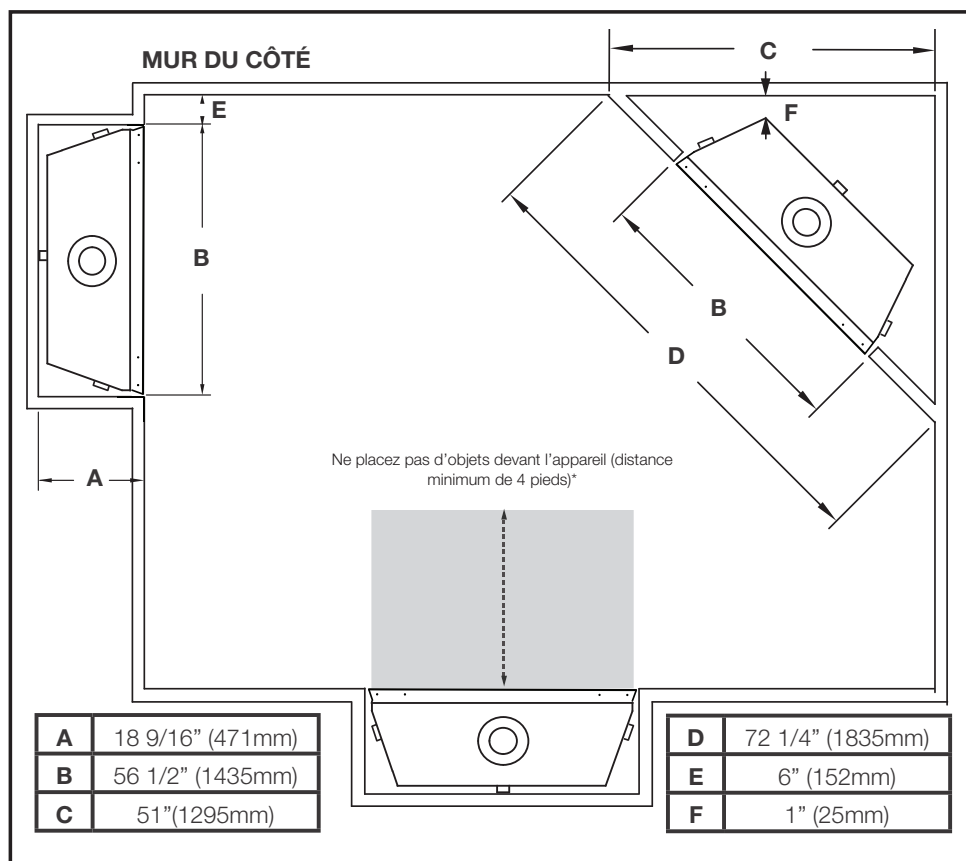

Dégagements Combustibles de la Tablette

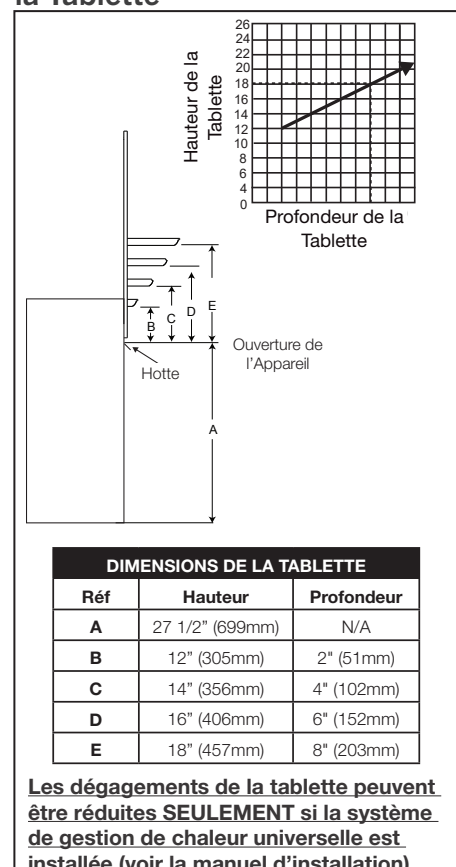

L'information du produit fourni n'est pas complet et est sujet de changer sans préavis. Consultez le manuel d'installation pour plus d'information d'installation actuel.

Pénétration du Mur

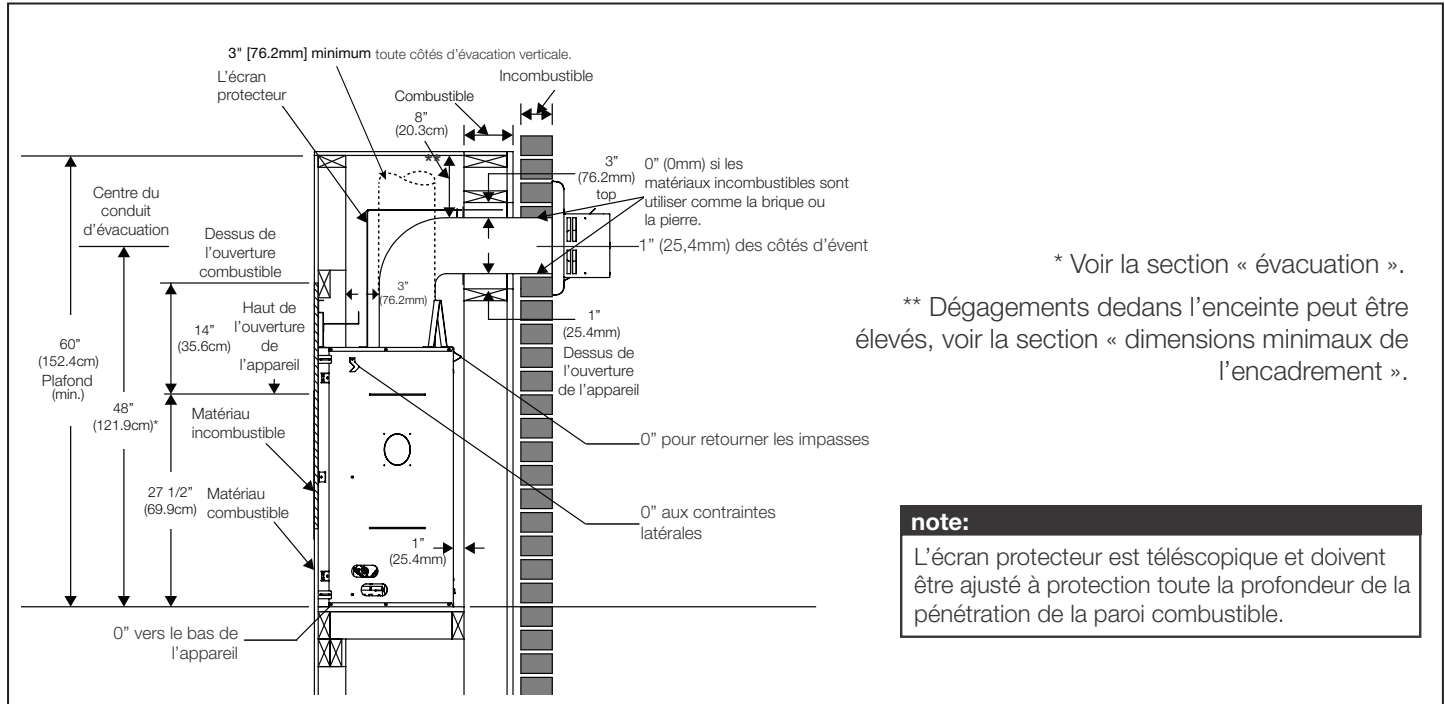

Ossature

⚠ AVERTISSEMENT

- Ne construisez pas dans cet espace de 14" (35,6cm) de largeur, centré le long de l'avant de l'appareil. Cet espace doit resté libre afin d'offrir un dégagement adéquat pour l'évacuation. Aucun matériaux combustible n'est permis.

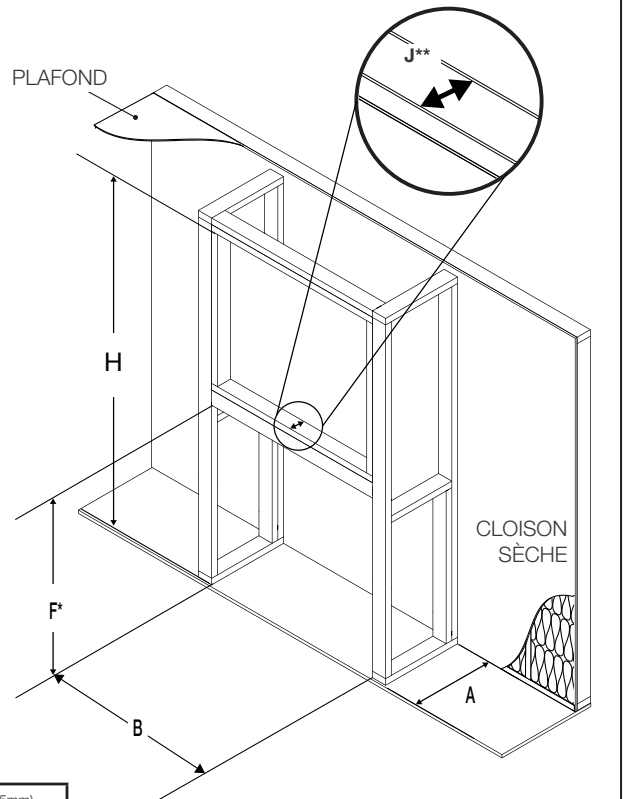
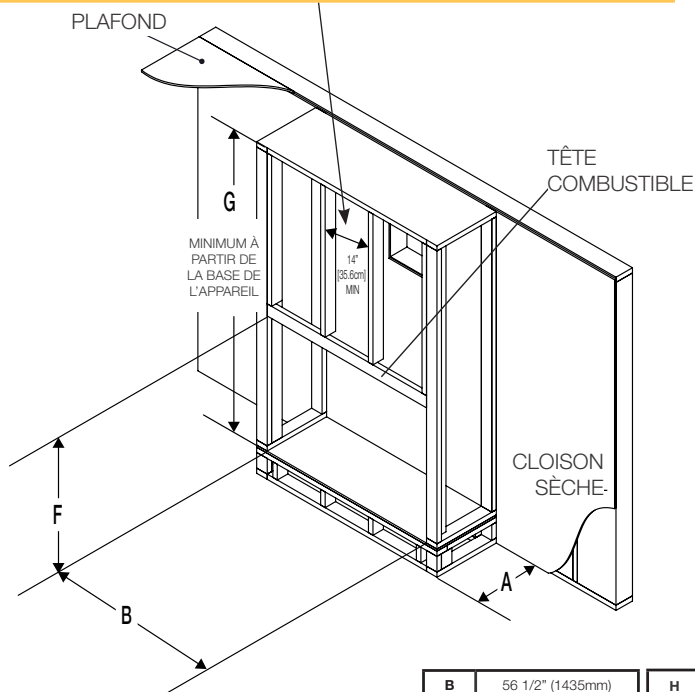

B	56 1/2" (1435mm)	H	84" (2135mm)
F	39 3/8" (1000mm)	I	3 1/2" (89mm)
A	18 9/16" (471mm)		
G	56" (1422mm)		

* Tenez compte de l'épaisseur du plancher et du foyer lorsque vous définissez ces dimensions.
** Le cadre de 2" x 4" peut être « renforcé » avec une pièce contreplaqué d'un épaisseur de 3/4" pour supporter le matériel de montage du téléviseur.